

TOSHIBA

430Series

*Maintenance
Manual*

PN: 430-9400

1.1 Features

The 430CDT/430CDS (430 Series) are two of the lightest and most advanced portable computers available. Utilizing advanced technology and high-speed components, the 430 series offers multimedia functions, excellent display legibility, battery operation and IBM PC/AT compatibility. The 430 series system unit has the following features:

- Microprocessor

Uses an Intel Pentium processor with Voltage Reduction Technology (VRT) that operates at 120 MHz and 3.3/2.9 volts.

- Disk storage

An internal 1.3 billion byte (1.26 GB) Hard Disk Drive (HDD). A 3.5-inch Floppy Disk Drive (FDD) supports 2HD (1.44 MB) floppy disks and 2DD (720 KB) floppy disks. The FDD can also be installed in an attachment for connection as an external device.

- CD-ROM Drive

A full-size, ten-speed (average) CD-ROM drive module can be installed instead of the FDD module. The CD-ROM drive contains an ATAPI (AT attachment packet interface) interface controller, and supports the following formats: audio CD, photo CD, CD-plus, and ISO 9660.

- Memory

Standard with 16 MB of CMOS RAM. This includes 640 KB of conventional memory and 15360 KB of extended memory, which can be utilized as expanded memory compatible with the Lotus/Intel/Microsoft Expanded Memory Specification (LIM-EMS).

- Display

The 430CDT has an 11.3-inch, Thin Film Transistor (TFT) color LCD with 800 x 600 pixels. The 430CDS has an 11.3-inch Dual-scan Supertwist Nematic (DSTN) color LCD with 800 x 600 pixels. The built-in display controller supports 800 x 600 resolution with 16M colors capability and up to 1280 x 1024 resolution with 256 colors on an external CRT.

- Keyboard

An-easy-to-use 82/84-key keyboard provides a numeric keypad overlay for fast numeric data entry or for cursor and page control. The keyboard supports software that uses a 101- or 102-key enhanced keyboard.

- Batteries

Three different batteries: a lithium-ion (Li-Ion) main battery, a backup battery (for memory backup), and an RTC battery (for Real Time Clock).

Expansion memory slot

An optional 8, 16, or 32 MB memory module can be installed in the memory slot.

Parallel port

Can be used to connect a Centronics compatible printer or other parallel device. The port supports ECP (Extended Capabilities Port) conforming to IEEE-1284.

Serial port (9-pin)

The serial controller is 16550UART compatible. This port can be used to connect such serial devices as a serial printer, serial mouse, or external modem.

External monitor port

The female, 15-pin, D-shell connector can be connected to an external SVGA monitor.

PS/2 mouse/keyboard port

Either a PS/2 compatible keyboard or a PS/2 compatible mouse can be connected to this port. The computer automatically recognizes which device is connected.

FDD port

This port enables a connection of the external FDD attachment if the CD-ROM module is installed inside the system unit.

PC card slot

A PC card slot accommodates two 5mm cards (Type II) or one 10.5mm (Type III) card, which support PCMCIA Release 2.01 cards. These slots also support advanced cards, including PC Card 16 multifunction cards as well as the Zoomed Video (ZV) port, which is dedicated to high-performance video data transfer such as MPEG video play back.

Enhanced Port Replicator port

This port enables connection of an Enhanced Port Replicator. The Enhanced Port Replicator has two PC card slots (Type III), and expands connections to the following devices: PS/2 keyboard, PS/2 mouse, serial port, parallel port, external CRT, joystick/MIDI port, audio line-in, audio line-out, headphone, external FDD, AC-in, AC-out, and rotary switch (ID select switch).

AccuPoint

A pointer control stick, located in the center of the keyboard, provides convenient control of the cursor without requiring desk space for a mouse.

Infrared port

Incorporates an IrDA1.0 (115.2Kbps supported) standard infrared transmitter and receiver.

□ Sound System

A Sound Blaster Pro compatible sound system provides capability to record sound and play it back with a built-in microphone and speaker. The sound system is equipped with a volume control dial, headphone jack, microphone jack, and audio line-in jack.

The 430 series Personal Computer is shown in Figure 1-1.

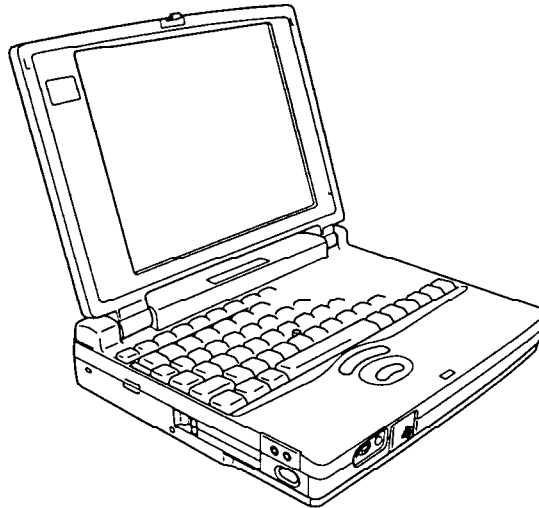

Figure 1-1 430 series personal computer

The 430 series system configuration is shown in Figure 1-2.

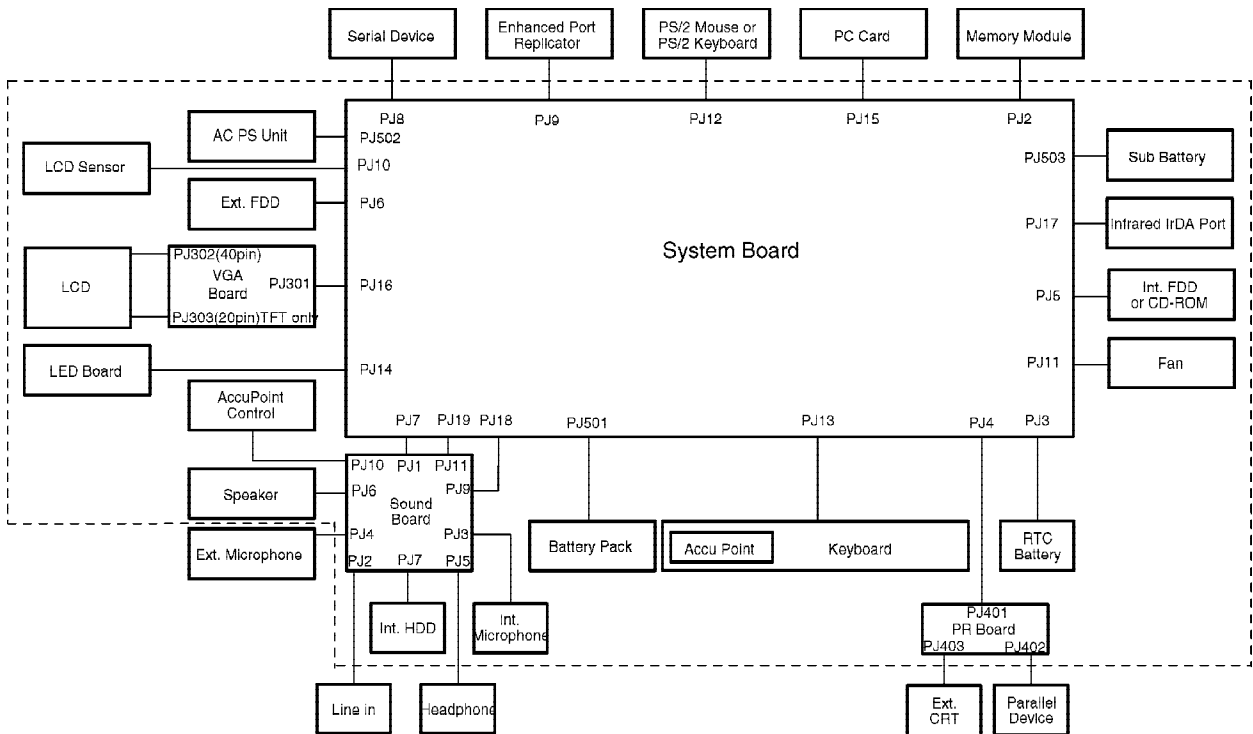

Figure 1-2 430 series system unit configuration

1.2 System Unit Block Diagram

Figure 1-3 is a block diagram of the 430 series system unit.

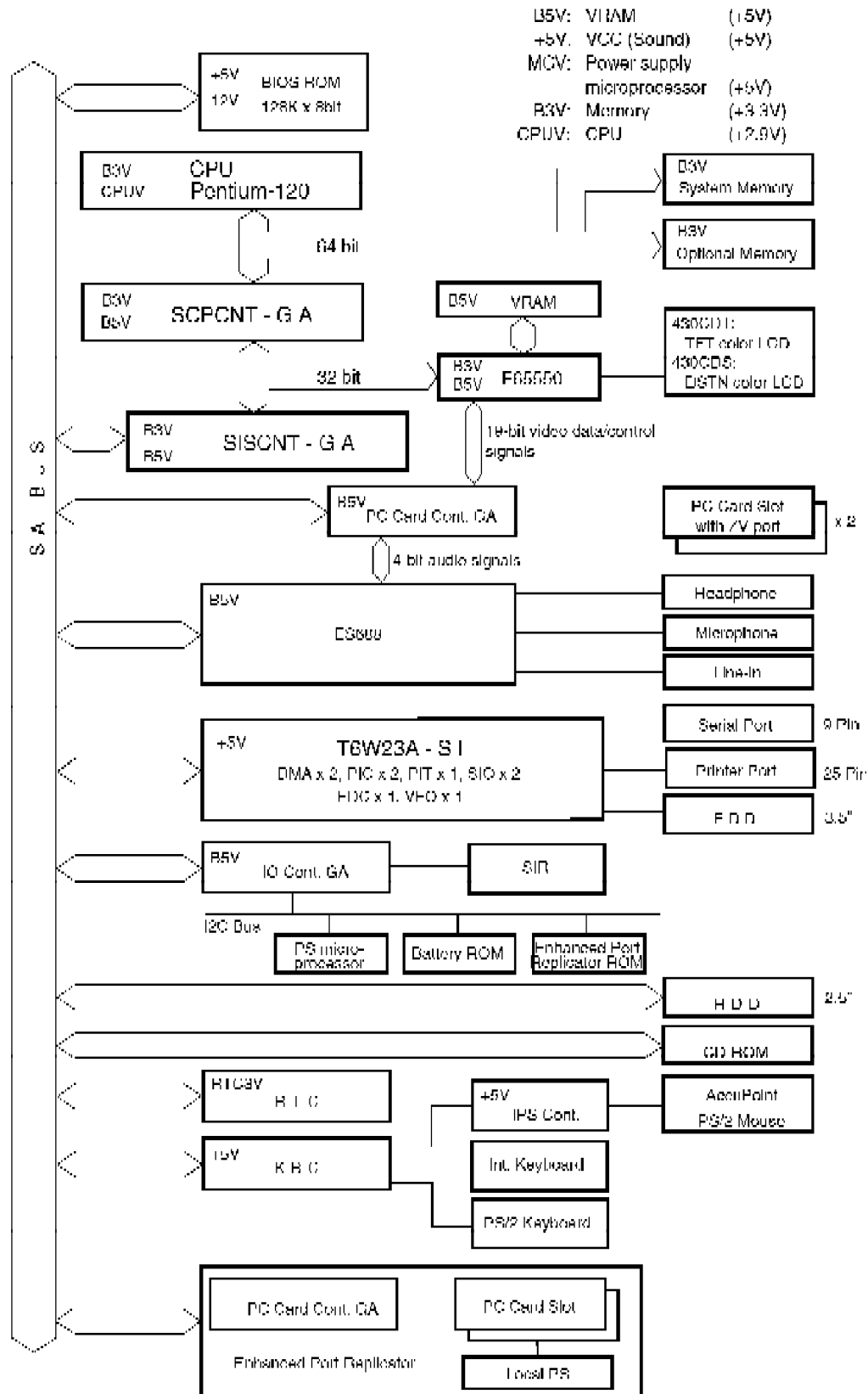

Figure 1-3 430 series system board block diagram

The 430 series system board is composed of the following major components:

- ❑ Microprocessor
 - One Intel Pentium processor with VRT 64-bit microprocessor
 - Intel Pentium processor which operates at 120 MHz and 3.3/2.9 volts.

- ❑ Standard RAM
 - 16 MB, eight 1Mx16-bit chips
 - 3.3 volt operation
 - No parity bit
 - Access time 60 ns
 - Data transfer is 64-bit width
 - EDO (extended data output) supported

- ❑ BIOS ROM (Flash EEPROM)
 - 128 KB (one 128Kx8-bit chip) memory
 - 64 KB in the ROM are used for system BIOS
 - 40 KB in the ROM are used for VGA BIOS
 - 24 KB in the ROM are reserved
 - Access time 150 ns
 - Data transfer is 8-bit width

- ❑ Video RAM
 - 2 MB (Four 256Kx16-bit DRAM)
 - 5 volt operation

- ❑ Optional memory
 - One expansion memory slot is available for 8, 16, and 32 MB memory modules, which consist of 1 MBx16-bit chips.
 - Total maximum memory size is 48 MB (if a 32 MB memory module is installed).
 - 3.3 volt operation
 - No parity bit
 - Access time 60 ns
 - Data transfer is 64-bit width
 - EDO (extended data output) supported

- ❑ One super integration (SI)
 - The following components:
 - Two DMACs 82C37 equivalent
 - Two PICs 82C59 equivalent
 - Two UART 16550 equivalent
 - One PIT 82C54 equivalent
 - One FDC TC8565 equivalent
 - One VFO TC8568 equivalent
 - One I/O port decode
 - One SIO port control
 - One printer port control supported ECP
 - One FDD control
 - One speaker control
 - One power communication control

❑ System Controller Gate Array (SCPCNT-GA)

This gate array has the following functions:

- CPU control
 - SMI control
 - CPU clock control
- Memory control
 - 64-bit bus memory control
 - 32-bit bus memory control
- Bus control
 - 64-bit data bus <==>32-bit data bus
 - 32-bit local bus control
- Address latch control
- I/O register control
- Processing speed control

❑ ISA Bus Controller Gate Array (SISCNT-GA)

This gate array has the following functions:

- Bus control
 - 32-bit data bus <==> 16-bit data bus
 - ISA bus interface control
 - ISA bus access control
 - DMAC control
 - DMA address generation
 - I/O control
 - Suspend/Resume sequence
- Memory control
 - ISA bus interface control
 - Refresh address generation
- I/O register control
- Suspend/Resume sequence

❑ PC Card Controller Gate Array

This gate array has the following functions:

- PCMCIA memory card control
- PCMCIA I/O card control

❑ I/O Controller Gate Array (IOCNT-GA)

This gate array has the following functions:

- Internal Communication controller
 - KBC, main CPU communication register file
 - KBC interrupt controller
 - KBC communication controller
 - I2C bus control
- Others
 - Speaker volume adjust PWM control
 - Sound board interface
 - BIOS-ROM interface
 - SMI control
 - IrDA (SIR) control

- ❑ Video Controller
Chips & Technologies F65550 is used.
This video controller controls internal TFT/DSTN color LCD and external SVGA compatible CRT.

- ❑ Keyboard Controller (KBC)
One M38802M4 chip is used.
This KBC includes the keyboard scan controller and keyboard interface controller. The KBC controls the internal keyboard, external keyboard, and PS/2 mouse.

- ❑ AccuPoint Controller (IPSC)
One KPAAC0062A chip is used.
This controller provides simultaneous control of both the AccuPoint and a PS/2 mouse.

- ❑ Real Time Clock (RTC)
One T9934 chip is used.
The T9934 has 128 bytes of memory. Fourteen bytes of memory are used for the calendar and clock. The remaining 114 bytes are used for the system configuration data.

1.3 3.5-inch Floppy Disk Drive

The 430 series 3.5-inch removable FDD is a thin, high-performance reliable drive that supports 720-KB (formatted) 2DD and 1.44-MB (formatted) 2HD disks. When a CD-ROM is installed in the Selectable Bay, an FDD attachment can be used to connect the FDD to an external FDD port.

The 430 series FDD is shown in Figure 1-4.

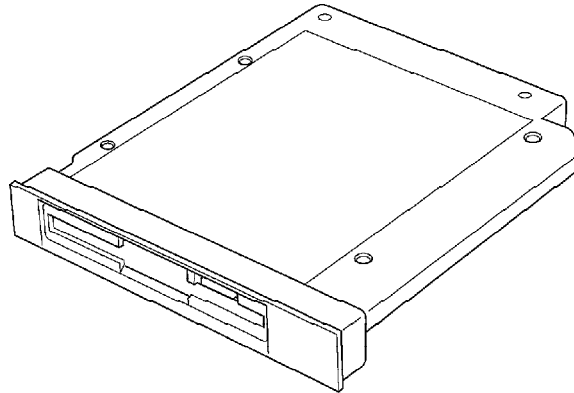

Figure 1-4 3.5-inch FDD

The specifications for the FDD are listed in Table 1-1.

Table 1-1 3.5-inch FDD specifications

Item	2-MB mode	1-MB mode
Storage capacity (KB)		
Unformatted	2,000	1,000
Formatted	1,475	737
Number of heads	2	2
Number of cylinders	80	80
Access time (ms)		
Track to track	3	3
Average	181	181
Head settling time	15	15
Recording track density (tpi)	135	135
Data transfer rate (Kbps)	500	250
Rotation speed (rpm)	300	300
Recording method	Modified Frequency Modulation (MFM)	

1.4 2.5-inch Hard Disk Drive

The Hard Disk Drive (HDD) is a random access non-volatile storage device. It has a non-removable 2.5-inch magnetic disk and mini-winchester type magnetic heads.

The 430 series supports the 1.3 billion byte (1.26GB) HDD which is shown in Figure 1-5.

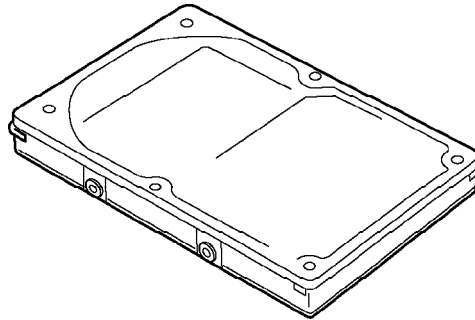

Figure 1-5 2.5-inch HDD

Specifications for the HDD are listed in Table 1-2.

Table 1-2 2.5-inch HDD specifications

Items	Toshiba MK1301MAV	IBM DMCA-21440	Seagate ST91350AG
Formatted capacity (byte)	1,358,880,768	1,445,068,800	1,350,107,136
Number of disks	3	2	3
Logical heads	16	16	16
Logical cylinders	2,633	2,800	2,616
Bytes per sector	512	512	512
Rotation speed (rpm)	4,200	4,000	4,500

1.5 Keyboard

The 82-(USA) or 84-(European) key keyboard is mounted on the 430 series system unit. The keyboard is connected to the keyboard controller on the system board through a 25-pin flat cable. The pointer control stick, located in the center of the keyboard, provides convenient control of the cursor without requiring desk space for a mouse. The keyboard is shown in Figure 1-6.

See Appendix E for optional keyboard configurations.

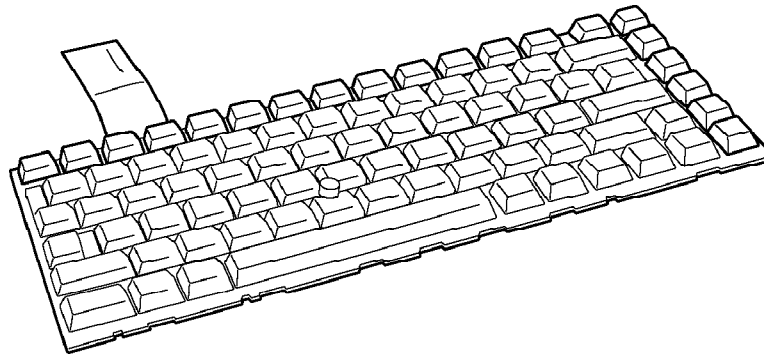

Figure 1-6 Keyboard

1.6 CD-ROM Drive

The 430 series internal CD-ROM drive accommodates either 12 cm (4.72-inch) or 8 cm (3.15-inch) CDs. It provides high-performance, ten-speed play (reads about 1,500KB per second). This drive supports the following formats:

- Audio CD
- Photo CD
- ISO 9660
- CD Plus

The CD-ROM drive is shown in Figure 1-7.

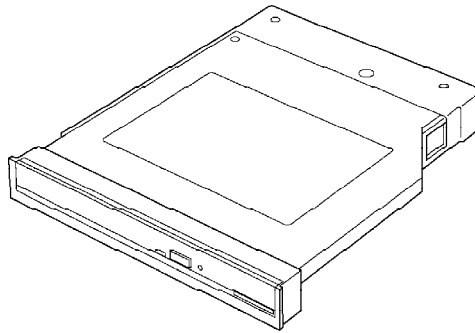

Figure 1-7 CD-ROM drive

The specifications for the CD-ROM drive are listed in Table 1-3.

Table 1-3 CD-ROM drive specifications

Item	1X mode	10X (ave.) mode
Data Capacity (bytes/block)		
Mode 1		2,048
Mode 2		2,336
Rotational Speed (rpm)	200 to 530	2,200 to 3,500
Transfer Rate		
Sustained Block Transfer (blocks/s)	75	750
Sustained Data Transfer (Kbytes/s)		
Mode 1	150	1,200
Mode 2	171	1,710
ATAPI Burst (Mbytes/s)	8.33 (PIO mode 2)	
Access Time (ms)		
Average Random Access	350	180
Average Random Seek	230	150
Average Full Stroke Access	500	320
Data Buffer Capacity (Kbytes)	128	

1.7 DSTN Color LCD (430CDS)

The DSTN Color Liquid Crystal Display (LCD) contains an LCD module, a Fluorescent Lamp (FL), and an FL inverter board.

1.7.1 DSTN Color LCD Module

The DSTN color LCD is backlit and supports 800x600 pixels with built-in display controller. This controller includes the functions of Video Graphics Array (VGA) and Super VGA (SVGA) for external display.

A display controller is F65550. This controller enables an LCD display of a maximum 64K colors.

The DSTN LCD is shown in Figure 1-8.

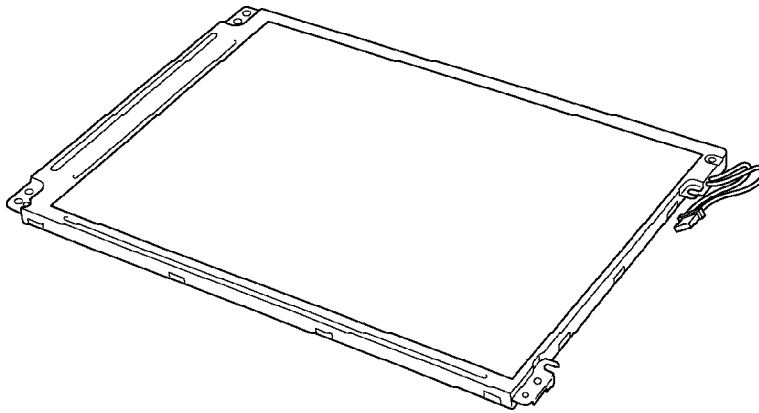

Figure 1-8 DSTN color LCD

The specifications for the LCD are listed in Table 1-4.

Table 1-4 DSTN color LCD specifications

Item		Specifications
Number of Dots	(dots)	800x600
Dot pitch	(mm)	0.288x0.288
Display area	(mm)	229.2 (W)x171 (H)
Contrast	(Typically)	27:1
FL current	(mA)	5.0/3.0 (Bright/Semi-bright)

1.7.2 DSTN Color Fluorescent Lamp (FL) Inverter Board

The FL inverter board supplies high frequency current to light the LCD Fluorescent Lamp. The specifications for the FL inverter are listed in Table 1-5.

Table 1-5 DSTN color FL inverter board specifications

Item		Specifications
Input	Voltage (V)	4 to 5.5
	Power (W)	4.25
Output	Voltage (Vrms)	1,100
	Current (mA)	5.0/3.0 (Bright/Semi-bright)

1.8 TFT Color LCD (430CDT)

The TFT Color Liquid Crystal Display (LCD) contains an LCD module, a Fluorescent Lamp (FL), and an FL inverter board.

1.8.1 TFT Color LCD Module

The TFT color LCD is backlit and supports 800x600 pixels with built-in display controller. This controller includes the functions of VGA and SVGA for external display.

A display controller is F65550. This controller enables an LCD display of a maximum 16M colors.

The TFT LCD is shown in Figure 1-9.

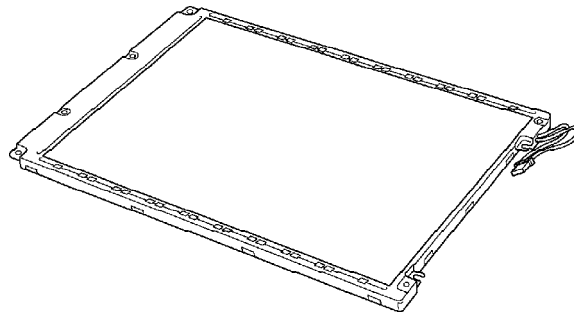

Figure 1-9 TFT color LCD

The specifications for the LCD are listed in Table 1-6.

Table 1-6 TFT color LCD specifications

	Item	Specifications
Number of dots	(dots)	800x600
Dot pitch	(mm)	0.288 (W)x0.288 (H)
Display area	(mm)	229.2 (W)x171 (H)
Contrast (minimum)		100:1
FL current	(mA)	2.4/2.8/4.0/4.6

***NOTE:** The FL currents at power on are:

	<i>Bright</i>	<i>Semi-bright</i>
<i>AC cord connected</i>	4.6 mA	2.8 mA
<i>AC cord not connected</i>	4.0 mA	2.4 mA

(The settings at power on do not change even if the AC cord connection changes.)

1.8.2 TFT Color Fluorescent Lamp (FL) Inverter Board

The FL inverter board supplies high frequency current to light the LCD Fluorescent Lamp. The specifications for the FL inverter are listed in Table 1-7.

Table 1-7 TFT color FL inverter board specifications

Item			Specifications
Input	Voltage	(V)	4 to 5.5
	Power	(W)	4.25
Output	Voltage	(Vrms)	1,100
	Current	(mA)	2.4/2.8/4.0/4.6

***NOTE:** *The FL currents at power on are:*

	<i>Bright</i>	<i>Semi-bright</i>
<i>AC cord connected</i>	<i>4.6 mA</i>	<i>2.8 mA</i>
<i>AC cord not connected</i>	<i>4.0 mA</i>	<i>2.4 mA</i>

(The settings at power on do not change even if the AC cord connection changes.)

1.9 Power Supply

The power supply provides five kinds of voltages to the 430 series system board. The power supply has one microprocessor, operates at 500 KHz, and performs the following functions:

1. Determines if the AC cable or battery is connected to the computer.
2. Detects AC output and circuit malfunctions.
3. Controls the LED icon and speaker.
4. Turns the battery charging system on and off and detects a fully charged battery.
5. Determines if the power can be turned on and off.
6. Provides more accurate detection of a low battery.
7. Calculates the remaining battery capacity.

The power supply output rating is specified in Table 1-8.

Table 1-8 Power supply output rating

Use for	Name	DC voltage	Regulation tolerance (%)
System logic, FDD, HDD, Display	VCC	+5	±5
CPU	CPUV	+2.9	±5
Flash ROM, PC card	12V	+12	±5
CPU, RAM, GA	B3V	+3.3	±0.3V
VRAM, GA	B5V	+4.7	±5

1.10 Batteries

The 430 series has three types of batteries:

- Main battery pack
- Backup battery
- Real Time Clock (RTC) battery

Battery specifications are listed in Table 1-9.

Table 1-9 Battery specifications

Battery name	Material	Output voltage	Capacity
Main battery	Lithium-Ion	10.8 V	3,600 mAH
Backup battery	Nickel Metal Hydride	7.2 V	110 mAH
RTC battery	Nickel Metal Hydride	3.6 V	30 mAH

1.10.1 Main Battery

The removable main battery pack is the computer's main power source when the AC power cord is not attached. The main battery recharges the backup battery. The backup and main battery maintain the state of the computer when you enable AutoResume.

- Battery Icon

The Battery icon is located on top of the back rim of the 430 series. The icon shows the status of the removable battery pack.

The status of each can be determined by color:

- Orange The battery is being charged. (AC power cord is attached.)
- Green The battery is fully charged. (AC power cord is attached.)
- Blink orange The battery is low when the power is on.
- No light Under any other conditions, the LED does not light.

1.10.2 Battery Charging Control

Battery charging is controlled by a power supply microprocessor. The microprocessor controls whether the charge is on or off and detects a full charge when the AC power cord and battery are attached to the computer. The system charges the battery using quick charge or trickle charge.

❑ Quick Battery Charge

When the AC power cord is attached, there are two types of charge: quick charge when the system is powered off and trickle charge when the system is powered on.

Table 1-10 Time required for quick charges

	Charging time
Power off	About 2 to 3 hours
Power on	About 5 to 8 hours

If one of the following occurs, the battery quick-charge process stops:

1. The battery becomes fully charged.
2. The battery is removed.
3. The battery or AC output voltage is abnormal.
4. The charge current is abnormal.

❑ Trickle Battery Charge

When the main battery is fully charged and the AC power cord is attached, the power supply microprocessor automatically changes from quick charge to trickle charge.

1.10.3 Backup Battery

The backup battery maintains data for AutoResume. The power source used to back up the AutoResume data is determined according to the following priority:

AC power > Main battery > Backup battery

The backup battery is charged by the main battery or AC power cord. Table 1-11 shows the charging time and data preservation period of the backup battery.

Table 1-11 Backup battery charging/data preservation time

		Time
Charging Time	Power On	20 H
	Power Off	20 H
Data preservation period (full charge)		4 H

1.10.4 RTC Battery

The RTC battery provides power to keep the current date, time, and other setup information in memory while the computer is turned off. Table 1-12 shows the charging time and data preservation period of the RTC battery.

Table 1-12 RTC battery charging/data preservation time

		Time
Charging Time	With AC power or main battery	48 H
Data preservation period (full charge)		1 month

2.1 Troubleshooting

Chapter 2 describes how to determine if a Field Replaceable Unit (FRU) in the 430 series is causing the computer to malfunction. The FRUs covered are:

1. Power Supply (Battery Pack, AC PS Unit)
2. System Board
3. Sound Board
4. VGA Board
5. Floppy Disk Drive
6. Hard Disk Drive
7. CD-ROM Drive
8. Keyboard
9. Display

The Diagnostics Disk operations are described in Chapter 3 and detailed replacement procedures are given in Chapter 4.

The following tools are necessary for implementing the troubleshooting procedures:

1. Diagnostics Disk
2. Phillips screwdriver (2 mm)
3. Toshiba MS-DOS system disk(s)
(You must install the following onto the disk: SYS.COM, FORMAT.COM, FDISK.COM and FDISK.EXE)
4. 2DD or 2HD formatted work disk for floppy disk drive testing
5. Cleaning kit for floppy disk drive troubleshooting
6. RS-232-C wraparound connector
7. Printer wraparound connector
8. Multimeter
9. External CRT
10. PS/2 or compatible keyboard
11. PS/2 or compatible mouse
12. PC card wraparound card
13. Multimedia sound system with line-in and line-out ports
14. Headphone
15. Toshiba EMI test disk TDY-03
16. Music CD
17. Serial Port Wraparound Connector
18. CD-ROM Drive
19. Lens cleaner for CD-ROM laser pickup lens

2.2 Troubleshooting Flowchart

Use the flowchart in Figure 2-1 as a guide for determining which troubleshooting procedures to execute. Before going through the flowchart steps, do the following:

- Ask the user if a password is registered and, if it is, ask him or her to enter the password. If the user has forgotten the system password, perform the following procedure *at the appropriate step in the flowchart in Figure 2-1*:

Connect the printer port wraparound board (F31PRT), then turn the POWER switch on. The computer will override the password function by erasing the current password.

- Verify with the customer that Toshiba MS-DOS is installed on the hard disk. Non-Toshiba operating systems can cause the computer to malfunction.
- Make sure all optional equipment is disconnected from the computer.
- Make sure the floppy disk drive is empty.

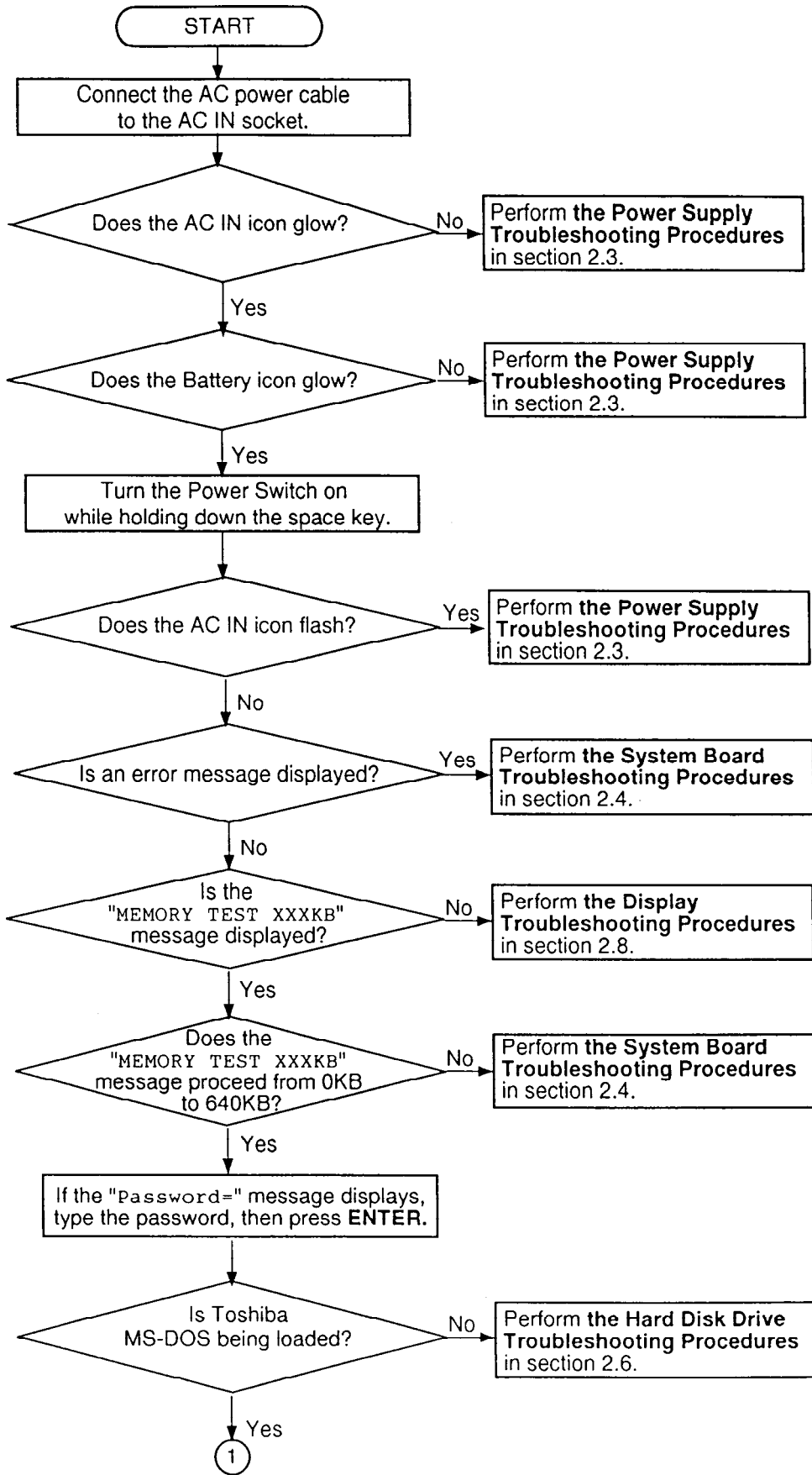

Figure 2-1 Troubleshooting flowchart

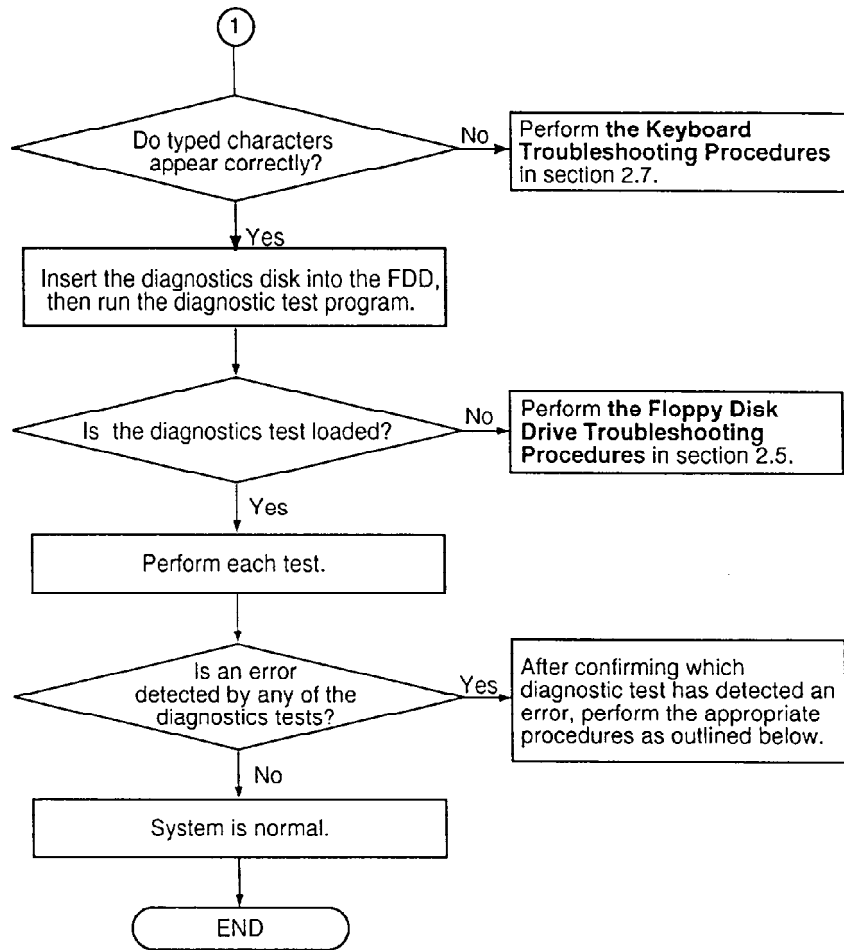

Figure 2-1 Troubleshooting flowchart (Continued)

If the diagnostics program cannot detect an error, the problem may be intermittent. The Running Test program should be executed several times to isolate the problem. Check the Log Utilities function to confirm which diagnostic test detected an error(s), then perform the appropriate troubleshooting procedures as follows:

1. If an error is detected on the system test, memory test, display test, ASYNC test, printer test, or real timer test perform the system board troubleshooting procedures in Section 2.4.
2. If an error is detected on the floppy disk test perform the floppy disk drive troubleshooting procedures in Section 2.5.
3. If an error is detected on the hard disk test perform the hard disk drive troubleshooting procedures in Section 2.6.
4. If an error is detected on the keyboard test perform the keyboard troubleshooting procedures in Section 2.7.
5. If an error is detected on the display test perform the display troubleshooting procedures in Section 2.8.
6. If an error is detected on the CD-ROM test perform the CD-ROM drive troubleshooting procedures in Section 2.9.

2.3 Power Supply Troubleshooting

The power supply controls many functions and components in the 430 series. To determine if the power supply is functioning properly, start with Procedure 1 and continue with the other procedures as instructed. The procedures described in this section are:

- Procedure 1: AC IN Icon Check
- Procedure 2: Battery Icon Check
- Procedure 3: AC PS Unit Replacement Check

Procedure 1 AC IN Icon Check

The AC PS unit converts AC power to DC power and contains a charging circuit which charges the 430 series batteries. The AC power cord connects to the AC IN socket connector on the back side of the computer. When the AC power cord is connected to the 430 series the AC PS unit charges the batteries.

The AC IN icon displays whether or not the AC power cord is connected and supplying power.

When the AC IN icon is green, the AC power cord is connected and supplying power to the 430 series.

If the AC IN icon does not light, the AC power cord is not supplying power to the 430 series or the AC power cord is not attached to the 430 series, go to Check 1.

If the AC IN icon is flashing orange, the AC power cord voltage supply is abnormal or the power supply is not functioning properly, go to Check 2.

If any of the above indicator conditions are abnormal, make sure the icon lights are not burned out before performing the following checks:

- Check 1 Make sure the correct AC power cord is firmly plugged into the AC IN socket on the back of the computer.
- Check 2 If the AC IN icon flashes orange when the AC power cord is connected, output voltage is abnormal. Connect a new AC power cord and turn the 430 series on again to verify the indicator condition.
- Check 3 The battery pack may be malfunctioning. Replace the battery pack with a new one and turn the computer on again. If the problem still exists, go to Procedure 2.

Procedure 2 Battery Icon Check

The Battery icon shows the battery charging status. The Battery icon glows orange when the AC power cord is charging the battery pack.

If the Battery icon glows green, the AC power cord is connected and the battery is fully charged.

If the Battery icon glows orange, the AC power cord is connected and the battery is being charged.

If the Battery icon does not glow, go to Check 1.

Check 1 Make sure the AC power cord is firmly plugged into the AC IN socket and wall outlet. If these cables are connected correctly, go to Check 2.

Check 2 Make sure the battery pack is installed in the computer correctly. If the battery pack is installed correctly, go to Check 3.

Check 3 Remove the battery pack and check that the battery terminal is clean and not bent.

If the terminal appears dirty, clean it gently with a cotton swab dipped in alcohol.

If the terminal looks bent or damaged, replace the system board.

If the battery terminal is clean and not bent, go to Check 4.

Check 4 Connect a new AC power cord. If the Battery icon still does not glow, go to Check 5.

Check 5 Install a new battery pack. If the Battery icon still does not glow, go to Procedure 3.

Procedure 3 AC PS Unit Replacement Check

The system board incorporates the power supply. Power is supplied to the system board through the AC IN plug located on the AC PS unit. The AC PS unit may be damaged, refer to Chapter 4 for instructions on how to disassemble the 430 series, and then perform the following checks:

Check 1 Replace the AC PS unit with a new one and restart the system. If the system is still not functioning properly, perform Check 2.

Check 2 Replace the system board with a new one and restart the system. If the problem still exists, other FRUs may be damaged.

2.4 System Board and Sound Board Troubleshooting

This section describes how to determine if the system board and sound board are defective or not functioning properly. Start with Procedure 1 and continue with the other procedures as instructed. The procedures described in this section are:

- Procedure 1: Message Check
- Procedure 2: Printer Port LED Check on Boot Mode
- Procedure 3: Printer Port LED Check on Resume Mode
- Procedure 4: Diagnostic Test Program Execution Check
- Procedure 5: Replacement Check

Procedure 1 Message Check

When the power is turned on, the system performs the Initial Reliability Test (IRT) installed in the BIOS ROM. The IRT tests each IC on the system board and initializes it.

- If an error message is shown on the display, perform Check 1.
- If there is no error message, go to Procedure 2.
- If the Toshiba MS-DOS is properly loaded, go to Procedure 3.

Check 1 If one of these error messages displays on the screen, press the **F1** key as the message instructs. These errors occur when data is lost or the system configuration preserved in the RTC memory (CMOS type memory) is not the same as the actual configuration.

If you press the **F1** key as the message instructs, the TSETUP screen appears to set the system configuration. If error message (b) appears often when the power is turned on, replace the RTC battery. If any other error message displays, perform Check 2.

- (a) *** Bad HDD type ***
Check system. Then press [F1] key
- (b) *** Bad RTC battery ***
Check system. Then press [F1] key
- (c) *** Bad configuration ***
Check system. Then press [F1] key
- (d) *** Bad memory size ***
Check system. Then press [F1] key
- (e) *** Bad time function ***
Check system. Then press [F1] key
- (f) *** Bad check sum (CMOS) ***
Check system. Then press [F1] key
- (g) *** Bad check sum (ROM) ***
Check system. Then press [F1] key

Check 2 If the following error message is displayed on the screen, press any key as the message instructs.

The following error message appears when data stored in RAM under the resume function is lost because the battery has become discharged or the system board is damaged. Go to Procedure 3. If any other message appears, perform Check 3.

```
WARNING: RESUME FAILURE.  
PRESS ANY KEY TO CONTINUE.
```

Check 3 The IRT checks the system board. When the IRT detects an error, the system stops or an error message appears.

If one of the following error messages (1) through (19), (26) or (27) is displayed, replace the system board.

If error message (20) is displayed, go to the Keyboard Troubleshooting Procedures in Section 2.7.

If error message (21), (22) or (23) is displayed, go to the HDD Troubleshooting Procedures in Section 2.6.

If error message (24) or (25) is displayed, go to the FDD Troubleshooting Procedures in Section 2.5.

- (1) BIOS is damaged
- (2) PIT ERROR
- (3) MEMORY REFRESH ERROR
- (4) TIMER CH.2 OUT ERROR
- (5) FIRST 64KB MEMORY ERROR
- (6) CMOS CHECKSUM ERROR
- (7) CMOS BAD BATTERY ERROR
- (8) FIRST 64KB MEMORY ERROR
- (9) FIRST 64KB MEMORY PARITY ERROR
- (10) VRAM ERROR
- (11) SYSTEM MEMORY ERROR
- (12) SYSTEM MEMORY PARITY ERROR
- (13) EXTENDED MEMORY ERROR
- (14) EXTENDED MEMORY PARITY ERROR
- (15) DMA PAGE REGISTER ERROR
- (16) DMAC #1 ERROR
- (17) DMAC #2 ERROR
- (18) PIC #1 ERROR
- (19) PIC #2 ERROR
- (20) KBC ERROR
- (21) HDC ERROR
- (22) HDD #0 ERROR
- (23) HDD #1 ERROR
- (24) NO FDD ERROR
- (25) FDC ERROR
- (26) TIMER INTERRUPT ERROR
- (27) RTC UPDATE ERROR

Procedure 2 Printer Port LED Check on Boot Mode

The printer port LED displays the IRT status and test status by turning lights on and off as an eight-digit binary value for boot mode. Figure 2-2 shows the printer port LED.

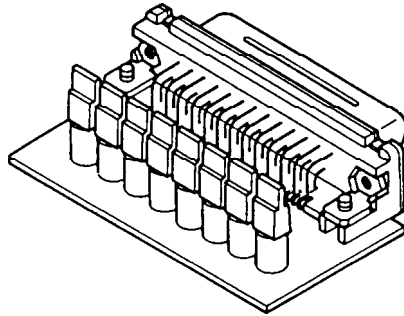

Figure 2-2 Printer port LED

To use the printer port LED follow these steps:

1. Turn on the power, then set to boot mode.
2. Turn off the power.
3. Plug the printer port LED into the parallel port.
4. Hold down the space bar and turn on the power.
5. Read the LED status from left to right as you are facing the back of the computer.
6. Convert the status from binary to hexadecimal notation.
7. If the final LED status is FFh (normal status), go to Procedure 3.
8. If the final LED status matches any of the test status values in Table 2-1, perform Check 1.

NOTE: *If an error condition is detected by the IRT test, the printer port LED displays an error code after the IRT test ends. For example, when the printer port LED displays 1F and halts, the IRT test has already completed the Display initialization. In this instance, the IRT indicates an error has been detected during the system memory test.*

Table 2-1 Printer port LED boot mode status

LED status	Test item	Message
01H	KBC initialization	
	ROM checksum test	BIOS is damaged!
02H	Special register initialization	
	PIT test	PIT ERROR
	PIT initialization	—
	PIT function check	MEMORY REFRESH ERROR TIMER CH.2 OUT ERROR
03H	CMOS check	CMOS CHECKSUM ERROR CMOS BAD BATTERY ERROR
	KB initialization	KBC ERROR
04H	Initialization of memory configuration	—
05H	SM-RAM check	—
06H	Self test check	—
	Read of Power Supply information	—
07H	ROM/RAM copy	—
08H	Initialization of internal VGA	—
0AH	First 64 KB memory test	FIRST 64KB MEMORY ERROR FIRST 64KB MEMORY PARITY ERROR
0BH	System memory initialization	—
0CH	System initialization	—
0DH	Interrupt vector initialization	—
18H	PIC initialization	—
1FH	Display initialization	VRAM ERROR
25H	System memory test	SYSTEM MEMORY ERROR SYSTEM MEMORY PARITY ERROR
30H	Extended memory test	EXTENDED MEMORY ERROR EXTENDED MEMORY PARITY ERROR
40H	DMA page register test	DMA PAGE REGISTER ERROR
41H	DMAC test	DMAC #X ERROR
42H	DMAC initialization	—
4AH	PIC test	PIC #X ERROR
50H	Mouse initialization	—
55H	KBC initialization	KBC ERROR
60H	HDD initialization	HDC ERROR/HDD #0 ERROR
65H	FDD initialization	FDC ERROR/NO FDD ERROR
70H	Printer initialization	—
80H	SIO initialization	—
90H	Timer initialization	RTC UPDATE ERROR TIMER INTERRUPT ERROR
A0H	NDP initialization	—

Table 2-1 Printer port LED boot mode status (Continued)

LED status	Test item	Message
A6H	Initialization of expansion ROM	—
C0H	Password check	—
FFH	Setup boot check	*** Bad xxxx xxxx *** Check system. Then press [F1] key.
FFH	Boot load	—

Check 1 If the following error codes are displayed, go to Procedure 5.

01h, 02h, 03h, 04h, 05h, 06h, 07h, 08h, 0Ah, 0Bh, 0Ch, 0Dh, 18h, 1Fh,
25h, 30h, 40h, 41h, 42h, 4Ah, 65h, 70h, 80h, 90h, A0h, A6h, C0h, FFh

Check 2 If error code 50h is displayed, go to the Keyboard Troubleshooting procedures in Section 2.7.

Check 3 If error code 55h is displayed, go to the HDD Troubleshooting Procedures in Section 2.6.

Check 4 If error code 60h is displayed, go to the FDD Troubleshooting Procedures in Section 2.5.

Procedure 3 Printer Port LED Check on Resume Mode

The printer port LED displays the IRT status and test status by turning lights on and off as an eight-digit binary value for resume mode.

To use the printer port LED follow these steps:

1. Turn on the power, then set to resume mode.
2. Turn off the power.
3. Plug the printer port LED into the parallel port.
4. Turn on the power.
5. Read the LED status from left to right as you face the back of the computer.
6. Convert the status from binary to hexadecimal notation.
7. If the final LED status is FFh (normal status), go to Procedure 3.
8. If the final LED status matches any of the test status values in Table 2-2, perform Procedure 5.

Table 2-2 Printer port LED resume mode error status

Error status	Meaning of status
F1H	RAM BIOS error
F2H	The system has optional ROM, or optional card (CGA, MDA)
F5H	Main memory checksum error
F6H	Video RAM checksum error
F7H	Extended memory checksum error

Procedure 4 Diagnostic Test Program Execution Check

Execute the following tests from the Diagnostic Test Menu. Refer to Chapter 3, *Tests and Diagnostics* for more information on how to perform these tests.

1. System test
2. Memory test
3. Printer test
4. ASYNC test
5. Real Timer test
6. NDP test
7. Expansion test
8. Sound test
9. CD-ROM test

If an error is detected during any of these tests, go to Procedure 5.

Procedure 5 Replacement Check

The system board or the sound board may be damaged. Disassemble the 430 series following the steps described in Chapter 4, *Replacement Procedures*, and perform the following checks:

- Check 1 Replace the system board with a new one. Refer to Chapter 4 for instructions on how to remove and replace the system board.
- Check 2 Replace the sound board with a new one. Refer to Chapter 4 for instructions on how to remove and replace the sound board.

NOTE: See Figure 1-2 in Chapter 1, *Hardware Overview*, for a view of the system board configuration.

2.5 Floppy Disk Drive Troubleshooting

This section describes how to determine if the 430 series internal or external 3.5-inch floppy disk drive is functioning properly. Perform the steps below starting with Procedure 1 and continuing with the other procedures as required.

Procedure 1: FDD Head Cleaning Check

Procedure 2: Diagnostic Test Program Execution Check

Procedure 3: Connector Check and Replacement Check

Procedure 1 FDD Head Cleaning Check

FDD head cleaning is one option available in the Diagnostic Program. Detailed operation is given in Chapter 3, *Tests and Diagnostics*.

After Toshiba MS-DOS loads, run the Diagnostic Program and then clean the FDD heads using the cleaning kit. If the FDD still does not function properly after cleaning, go to Procedure 2.

If the test program cannot be executed on the 430 series, go to Procedure 3.

Procedure 2 Diagnostic Test Program Execution Check

The Floppy Disk Drive Diagnostic Test program is stored on the 430 series Diagnostics Disk. After loading Toshiba MS-DOS, run the diagnostic program. Refer to Chapter 3, *Tests and Diagnostics*, for more information about the diagnostics test procedures.

Floppy disk drive test error codes and their status names are described in Table 2-3. Make sure the floppy disk in the FDD is formatted correctly and that the write protect tab is disabled. If any other errors occur while executing the FDD diagnostics test, go to Check 1.

Table 2-3 Floppy disk drive error codes and statuses

Code	Status
01h	Bad command
02h	Address mark not found
03h	Write protected
04h	Record not found
06h	Media removed on dual attach card
08h	DMA overrun error
09h	DMA boundary error
10h	CRC error
20h	FDC error
40h	Seek error
60h	FDD not drive
80h	Time out error (Not ready)
EEh	Write buffer error
FFh	Data compare error

Check 1 If the following message is displayed, disable the write protect tab on the floppy disk.

Write protected

If any other message appears, perform Check 2.

Check 2 Make sure the floppy disk is formatted correctly. If it is, go to Procedure 3.

Procedure 3 Connector Check and Replacement Check

The 3.5-inch Floppy Disk Drive is connected to the FDD port by the FDD cable. This cable may be damaged or disconnected from the external 3.5-inch FDD port. Do the following checks:

Check 1 Make sure the FDD cable is firmly connected to the FDD port.

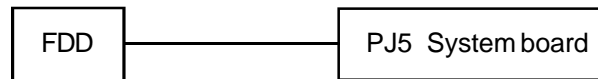

If this cable is disconnected, connect it to the system unit and repeat Procedure 2. If the FDD is still not functioning properly, perform Check 2.

Check 2 The cable may be defective or damaged. Replace the cable. If the FDD is still not functioning properly, perform Check 3.

Check 3 The FDD or its cable may be defective or damaged. Replace the FDD with a new one following the steps in Chapter 4, *Replacement Procedures*. If the FDD is still not functioning properly, perform Check 4.

Check 4 Replace the system board with a new one following the steps in Chapter 4.

2.6 Hard Disk Drive Troubleshooting

To determine if the hard disk drive is functioning properly, perform the procedures below starting with Procedure 1. Continue with the other procedures as instructed.

- Procedure 1: Partition Check
- Procedure 2: Message Check
- Procedure 3: Format Check
- Procedure 4: Diagnostic Test Program Execution Check

NOTE: *The contents of the hard disk will be erased when the HDD troubleshooting procedures are executed. Before running the procedures, transfer the contents of the hard disk to floppy disk as follows:*

Check to see if the Microsoft Create System Disks Tools (MSCSD.EXE) still exists in the System Tools Folder. (This tool can be used only once.) If it exists, use it to back up the preinstalled software, then use the Backup utility in the System Tools folder to back up the entire disk, including the user's files.

Refer to the operating system instructions for more information.

Procedure 1 Partition Check

Insert the Toshiba MS-DOS system disk and turn on the computer. Then perform the following checks:

- Check 1 Type **C:** and press **Enter**. If you cannot change to drive C, go to Check 2. If you can change to drive C, go to Procedure 2.
- Check 2 Type **FDISK** and press **Enter**. Choose "Display Partition Information" from the FDISK menu. If drive C is listed, go to Check 3. If drive C is not listed, return to the FDISK menu and choose the option to create a DOS partition on drive C. Recheck the system. If the problem still exists, go to Procedure 2.
- Check 3 If drive C is listed as active on the FDISK menu, go to Check 4. If drive C is not listed as active, return to the FDISK menu and choose the option to set the active partition for drive C. Recheck the system. If the problem still exists, go to Procedure 2.
- Check 4 Remove the system disk from the FDD and cold boot the computer. If the problem still exists, go to Procedure 2. Otherwise, the HDD is operating normally.

Procedure 2 Message Check

When the HDD does not function properly, some of the following error messages may appear on the display. Start with Check 1 below and perform the other checks as instructed.

Check 1 If any of the following messages appear, perform Check 2. If the following messages do not appear, perform Check 4:

```
HDC ERROR
  (After 5 seconds this message will disappear.)
      or
HDD #0 ERROR
  (After 5 seconds this message will disappear.)
      or
HDD #1 ERROR
  (After 5 seconds this message will disappear.)
```

Check 2 If either of the following messages appears, perform Procedure 3. If the following messages do not appear, perform Check 3.

```
Insert system disk in drive
Press any key when ready .....
      or
Non-System disk or disk error
Replace and press any key
```

Check 3 Using the Toshiba MS-DOS system disk, install a system program on the hard disk using the SYS command.

If the following message appears on the display, the system program has been transferred to the HDD. Restart the 430 series. If the error message still appears, perform Check 4.

```
System transferred
```

Check 4 The HDD is connected to the system board directly. This connection can become disconnected or damaged. Disassemble the 430 series as described in Chapter 4, *Replacement Procedures*. If the HDD is not connected, connect it to the system board and return to Procedure 1. If the HDD is firmly connected to the system board, perform Procedure 3.

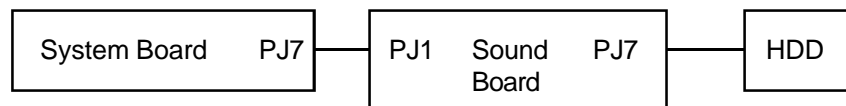

Procedure 3 Format Check

The HDD is formatted using the low level format program and the MS-DOS FORMAT program. To format the HDD, start with Check 1 below and perform the other check as required.

- Check 1 Using the Toshiba MS-DOS system disk, partition the hard disk using the FDISK command. Format the hard disk using **FORMAT C:/S/U** to transfer the system program to the HDD. If the following message appears on the display, the HDD is formatted.

```
Format complete
```

If any other error message appears on the display, refer to the *Toshiba MS-DOS Manual* for more information and perform Check 2.

- Check 2 Using the 430 series Diagnostic Disk, format the HDD with a low level format option. Refer to Chapter 3, *Tests and Diagnostics*, for more information about the diagnostic program.

If the following message appears on the display, the HDD low level format is complete. Partition and format the HDD using the MS-DOS FORMAT command.

```
Format complete
```

If you cannot format the HDD using the Test and Diagnostic program, go to Procedure 4.

Procedure 4 Diagnostic Test Program Execution Check

The HDD test program is stored on the 430 series Diagnostics Disk. Perform all of the HDD tests in the Hard Disk Drive Test. Refer to Chapter 3, *Tests and Diagnostics*, for more information about the HDD test program.

If an error is detected during the HDD test, an error code and status will be displayed. Perform Check 1. The error codes and statuses are described in Table 2-4. If an error code is not generated, the HDD is operating properly.

Table 2-4 Hard disk drive error codes and statuses

Code	Status
01h	Bad command
02h	Bad address mark
04h	Record not found
05h	HDC not reset
07h	Drive not initialized
08	HDC overrun (DRQ)
09h	DMA boundary error
0Ah	Bad sector error
0Bh	Bad track error
10h	ECC error
11h	ECC recover enabled
20h	HDC error
40h	Seek error
80h	Time out error
AAh	Drive not ready
BBh	Undefined error
CCh	Write fault
E0h	Status error
EEh	Access time out error
FFh	Data compare error

Check 1 Replace the HDD unit with a new one following the instructions in Chapter 4, *Replacement Procedures*. If the HDD is still not functioning properly, perform Check 2.

Check 2 Replace the system board with a new one following the instructions in Chapter 4.

2.7 Keyboard Troubleshooting

To determine if the 430 series keyboard is functioning properly, perform the following procedures. Start with Procedure 1 and continue with the other procedure as instructed.

Procedure 1: Diagnostic Test Program Execution Check

Procedure 2: Connector and Replacement Check

Procedure 1 Diagnostic Test Program Execution Check

Execute the Keyboard Test in the Diagnostic Program. Refer to Chapter 3, *Tests and Diagnostics*, for more information on how to perform the test program.

If an error occurs, go to Procedure 2. If an error does not occur, the keyboard is functioning properly.

Procedure 2 Connector and Replacement Check

The keyboard is connected to the system board by a flat cable. This cable may be disconnected or damaged. Disassemble the 430 series as described in Chapter 4, *Replacement Procedures*, and perform the following checks:

Check 1 Make sure the keyboard cable is not damaged and is connected to the system board.

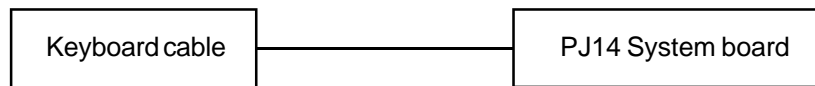

If this cable is damaged, replace the keyboard with a new one. If the cable is disconnected, firmly connect it. Perform Procedure 1 again. If the keyboard is still not functioning properly, perform Check 2.

Check 2 The keyboard controller on the system board may be damaged. Replace the system board with a new one. Refer to Chapter 4 for more information.

2.8 Display and VGA Board Troubleshooting

This section describes how to determine if the 430 series display is functioning properly. Start with Procedure 1 and continue with the other procedures as instructed.

- Procedure 1: Contrast Control Check (430CDS only)
- Procedure 2: External CRT Check
- Procedure 3: Diagnostic Test Program Execution Check
- Procedure 4: Connector Check
- Procedure 5: Replacement Check

Procedure 1 Contrast Control Check (430CDS only)

Contrast is adjusted by the contrast dial. If the contrast does not change when you turn the contrast dial, perform Procedure 2.

Procedure 2 External CRT Check

Connect the external CRT to the 430 series external monitor port, then boot the computer. The computer automatically detects the external CRT even if Resume mode is enabled.

If the external CRT works correctly, the internal LCD display may be damaged. Go to Procedure 4.

If the external CRT appears to have the same problem as the internal LCD, the display controller may be damaged. Go to Procedure 3.

Procedure 3 Diagnostic Test Program Execution Check

The Display Test program is stored on the 430 series Diagnostics Disk. This program checks the display controller on the VGA board. After loading Toshiba MS-DOS, run the Diagnostic Program. Refer to Chapter 3, *Tests and Diagnostics*, for details.

If an error is detected, go to Procedure 4. If an error is not detected, the display is functioning properly.

Procedure 4 Connector Check

The Display unit has an LCD module, FL, Display switch, and FL inverter board. The FL and FL inverter board are connected by two cables. The LCD module and VGA board are connected as shown below. Any of these cables may be disconnected.

Disassemble the display unit and check the following cable connections. Refer to Chapter 4, *Replacement Procedures*, for more information about how to disassemble the computer.

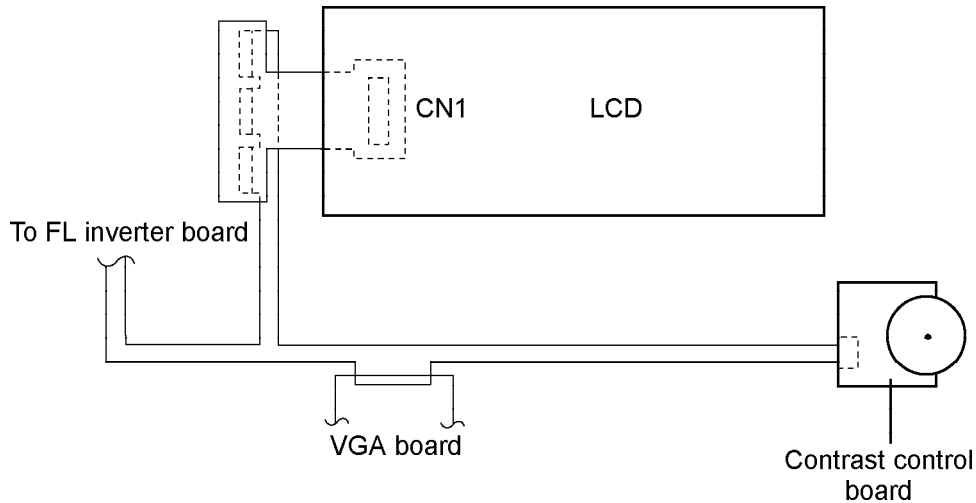

Figure 2-3 430CDS display connection

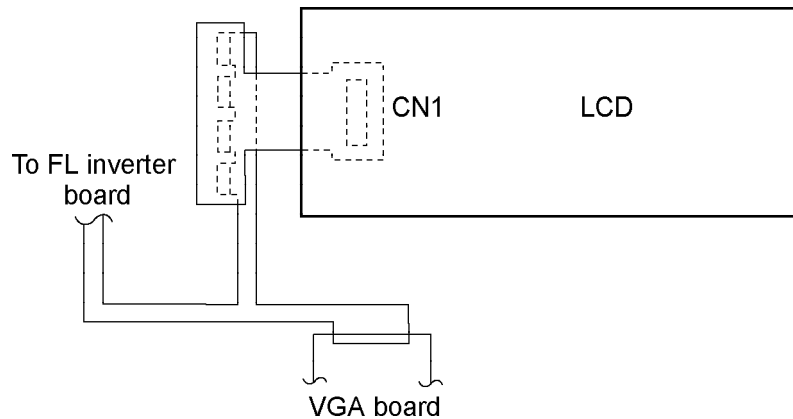

Figure 2-4 430CDT display connection

Firmly reconnect any cable which has become disconnected, then repeat Procedures 1 and 2. If the problem still exists, perform Procedure 5.

Procedure 5 Replacement Check

The FL, FL inverter board, LCD module, and system board are connected to the display circuits. Any of these components may be damaged. Refer to Chapter 4, *Replacement Procedures*, for instructions on how to disassemble the computer and then perform the following checks:

If the FL does not light, perform Check 1.

If characters are not displayed clearly, perform Check 3.

If some screen functions do not operate properly, perform Check 3.

If the FL remains lit when the display is closed, perform Check 4.

- Check 1 Replace the FL with a new one and test the display again. If the problem still exists, perform Check 2.
- Check 2 Replace the FL inverter board with a new one and test the display again. If the problem still exists, perform Check 3.
- Check 3 Replace the LCD module with a new one and test the display again. If the problem still exists, perform Check 4.
- Check 4 Replace the display switch with a new one and test the display again. If the problem still exists, perform Check 5.
- Check 5 Replace the display cable with a new one and test the display again. If the problem still exists, perform Check 6.
- Check 6 The system board or VGA board may be damaged. Replace it with a new one.

2.9 CD-ROM Drive Troubleshooting

This section describes how to determine if the 430 series internal CD-ROM drive is functioning properly. Perform the steps below starting with Procedure 1 and continuing with the other procedures as required.

Procedure 1: CD Cleaning Check

Procedure 2: Diagnostic Test Program Execution Check

Procedure 3: Connector Check and Replacement Check

Procedure 1 CD Cleaning Check

Clean the laser pickup lens with a lens cleaner. Apply the cleaner to a cloth and wipe the lens.

If the CD-ROM drive still does not function properly after cleaning, go to Procedure 2.

Procedure 2 Diagnostic Test Program Execution Check

The CD-ROM drive Diagnostic Test program is stored on the 430 series Diagnostics Disk. After Toshiba MS-DOS loads, run the diagnostic program stored on the Diagnostics Disk. Insert a test CD (Toshiba-EMI Test Disc TDY-03) into the CD-ROM drive and run the test. Refer to Chapter 3, *Tests and Diagnostics*, for more information about the diagnostics test procedures.

If any other errors occur while executing the CD-ROM drive diagnostics test, go to Procedure 3.

Procedure 3 Connector Check and Replacement Check

The CD-ROM drive is connected to the system board by the CD-ROM drive cable. This cable may be damaged or disconnected from the system board. Disassemble the 430 series following the steps described in Chapter 4, *Replacement Procedures*, and perform the following checks:

Check 1 Make sure the CD-ROM is firmly connected to the system board.

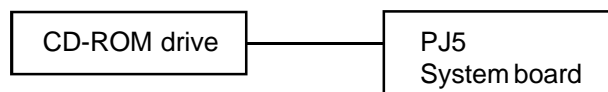

If this cable is disconnected, connect it to the system unit and repeat Procedure 2. If the CD-ROM is still not functioning properly, perform Check 2.

Check 2 The CD-ROM drive may be defective or damaged. Replace the CD-ROM drive with a new one following the steps in Chapter 4. If the CD-ROM drive is still not functioning properly, perform Check 3.

Check 3 Replace the system board with a new one following the steps in Chapter 4.

3.1 The Diagnostic Test

This chapter explains how to use the Diagnostic Test program to test the functions of the computer's hardware modules. The Diagnostics Program is stored on the Diagnostics Disk and consists of nine programs that are grouped into the Service Program Module (DIAGNOSTICS MENU).

- NOTES:** *To start the diagnostics, follow these steps:*
1. *Check all cables for loose connections.*
 2. *Exit any application you may be using and close Windows.*

The DIAGNOSTIC MENU consists of the following nine functions.

- DIAGNOSTIC TEST
- HARD DISK FORMAT
- HEAD CLEANING
- LOG UTILITIES
- RUNNING TEST
- FDD UTILITIES
- SYSTEM CONFIGURATION
- EXIT TO MS-DOS
- SETUP

The DIAGNOSTIC TEST MENU contains the following functional tests:

- SYSTEM TEST
- MEMORY TEST
- KEYBOARD TEST
- DISPLAY TEST
- FLOPPY DISK TEST
- PRINTER TEST
- ASYNC TEST
- HARD DISK TEST
- REAL TIMER TEST
- NDP TEST
- EXPANSION TEST
- SOUND TEST
- CD-ROM TEST

You will need the following equipment to perform some of the Diagnostic test programs.

- The Diagnostics Disk (all tests)
- A formatted working disk for the floppy disk drive test (all tests)
- An external FDD attachment
- A cleaning kit to clean the floppy disk drive heads (Head Cleaning)
- A PC card wraparound connector for the I/O card test (Expansion test)
- A printer wraparound connector for the printer wraparound test (Printer test)
- An RS-232-C wraparound connector for the RS-232-C port wraparound test (ASYNC test)
- A CD test media (Toshiba-EMI test disk TDY-03 and music CD) (CD-ROM test)
- External CRT (All tests)
- PS/2 or compatible keyboard (All tests)
- PS/2 or compatible mouse (Keyboard test)
- Serial Port wraparound connector (ASYNC test)
- Multimedia sound system with line-in and line-out ports (Sound test)
- Headphone (Sound test)
- A microphone
- A music CD

The following sections detail the tests within the Diagnostic Test function of the DIAGNOSTIC TEST MENU. Refer to Sections 3.19 through 3.25 for detailed information on the remaining Service Program Module functions.

3.2 Executing the Diagnostic Test

Toshiba MS-DOS is required to run the DIAGNOSTICS PROGRAM. To start the DIAGNOSTIC PROGRAM follow these steps:

1. Insert the Diagnostics disk in the floppy disk drive and turn on the computer. The Diagnostics disk contains the MS-DOS boot files.

NOTE: To execute the CD-ROM test, make sure the CD-ROM and CD-ROM drive are installed in the computer and the external FDD is attached to the FDD port.

The following menu will appear:

```
TOSHIBA personal computer xxx DIAGNOSTICS
version X.XX (c) copyright TOSHIBA Corp. 19XX
```

```
DIAGNOSTICS MENU :
```

```
1 - DIAGNOSTIC TEST
2 - HARD DISK FORMAT
3 -
4 - HEAD CLEANING
5 - LOG UTILITIES
6 - RUNNING TEST
7 - FDD UTILITIES
8 - SYSTEM CONFIGURATION
9 - EXIT TO MS-DOS
0 - SETUP
```

```
↑↓→← : Select items
Enter : Specify
Esc   : Exit
```

NOTE: To exit the DIAGNOSTIC TEST MENU, press the **Esc** key. If a test program is in progress, press **Ctrl + Break** to exit the test program or press **Ctrl + C** to stop the test program.

- To select the DIAGNOSTIC TEST MENU from the DIAGNOSTICS MENU, set the highlight bar to **1**, and press **Enter**. The following screen will appear:

```

TOSHIBA personal computer xxx DIAGNOSTICS
version X.XX (c) copyright TOSHIBA Corp. 19XX
DIAGNOSTIC TEST MENU :

1 - SYSTEM TEST
2 - MEMORY TEST
3 - KEYBOARD TEST
4 - DISPLAY TEST
5 - FLOPPY DISK TEST
6 - PRINTER TEST
7 - ASYNC TEST
8 - HARD DISK TEST
9 - REAL TIMER TEST
10 - NDP TEST
11 - EXPANSION TEST
12 - SOUND TEST
13 - CD-ROM TEST
88 - ERROR RETRY COUNT SET [HDD & FDD]
99 - EXIT TO DIAGNOSTICS MENU

      ↑↓→←   :   Select items
      Enter   :   Specify
      Esc     :   Exit

```

Refer to sections 3.4 through 3.16 for detailed descriptions of Diagnostic Tests 1 through 13. Function 88 sets the floppy disk drive and hard disk drive error retry count. Function 99 exits the submenus of the Diagnostic Test and returns to the Diagnostic Menu.

- Select the option you want to execute and press **Enter**. The following message will appear:

```

SYSTEM TEST      XXXXXXXX

                                     xxx DIAGNOSTIC TEST VX.XX
                                     [Ctrl]+[Break]; test end
                                     [Ctrl]+[C]   ; key stop

SUB-TEST : XX
PASS COUNT: XXXXX ERROR COUNT: XXXXX
WRITE DATA: XX READ DATA : XX
ADDRESS : XXXXXX STATUS : XXX

SUB-TEST MENU :

01 - ROM checksum
02 -
03 -
04 - Fan ON/OFF
05 - Thermistor check
99 - Exit to DIAGNOSTIC TEST MENU

      ↑↓→←   :   Select items
      Enter   :   Specify
      Esc     :   Exit

```

NOTE: The menu displayed by your computer may be slightly different from the one shown above.

4. Select the desired subtest number from the subtest menu and press **Enter**. The following message will appear:

```
TEST LOOP   : YES
ERROR STOP  : YES
```

Selecting **YES** for *TEST LOOP* sets the test to run continuously until it is halted by the user. Selecting **NO** returns the screen to the main menu after the test is complete.

Selecting **YES** for *ERROR STOP* stops the test program when an error is found and displays the operation guide on the right side of the display screen as shown below:

```
ERROR STATUS NAME    [[ HALT OPERATION ]]

                                1: Test end
                                2: Continue
                                3: Retry
```

These three selections have the following functions, respectively:

- 1: Terminates the test program and exits to the subtest menu.
- 2: Continues the test.
- 3: Restarts the test from the error.

Use the arrow keys to move the cursor to the desired option and press **Enter**.

Selecting **NO** for *ERROR STOP* keeps the test running even if an error is found.

Table 3-1 in Section 3.3 describes the function of each test on the subtest menu. Table 3-2 in Section 3.17 describes the error codes and error statuses for each error.

3.3 Subtest Names

Table 3-1 lists the subtest names for each test program in the DIAGNOSTIC TEST MENU.

Table 3-1 Subtest names

No.	Test name	Subtest No.	Subtest item
1	SYSTEM	01	ROM checksum
		04	Fan ON/OFF
		05	Thermistor check
2	MEMORY	01	RAM constant data
		02	RAM address pattern data
		03	RAM refresh
		04	Protected mode
		05	Memory module
		06	Cache memory
3	KEYBOARD	01	Pressed key display
		02	Pressed keycode display
		03	PS/2 Mouse connect check
		04	Pointing stick
4	DISPLAY	01	VRAM read/write for VGA
		02	Gradation for VGA
		03	Gradation for LCD
		04	Gradation & Mode test for VGA
		05	All dots on/off for LCD
		06	"H" pattern display
5	FDD	01	Sequential read
		02	Sequential read/write
		03	Random address/data
		04	Write specified address
		05	Read specified address
6	PRINTER	01	Ripple pattern
		02	Function
		03	Wraparound

Table 3-1 Subtest names (Continued)

No.	Test name	Subtest No.	Subtest item
7	ASYNC	01	Wraparound (board)
		02	Board(#1) <=> board(#2)
		03	Point to point (send)
		04	Point to point (receive)
		05	Interrupt test
		06	Infra_red Wrap_around test
		07	Infra_red Transmit mode
		08	Infra_red Receive mode
8	HDD	01	Sequential read
		02	Address uniqueness
		03	Random address/data
		04	Cross talk & peak shift
		05	Write/read/compare (CE)
		06	Write specified address
		07	Read specified address
		08	ECC circuit
		09	Sequential write
		10	W-R-C specified address
9	REAL TIMER	01	Real time
		02	Backup memory
		03	Real time carry
10	NDP	01	NDP test
11	EXPANSION	01	PCMCIA wrap around (Internal)
		02	PCMCIA wrap around (External)
12	SOUND	01	CODEC (REC/PLAY)
		02	FM-Synthesizer
		03	SINE-wave playback
		04	Joystick
		05	Joystick/MIDI wrap around
		06	CODEC (Line In/Out)
13	CD-ROM	01	Sequential read
		02	Read specified address
		03	Random address/data
		04	Playback Music

3.4 System Test

To execute the System Test select **1** from the DIAGNOSTIC TEST MENU, press **Enter** and follow the directions displayed on the screen. Move the highlight bar to the subtest you want to execute and press **Enter**.

Subtest 01 ROM checksum

This subtest executes a checksum test of the BIOS ROM on the system board.

Subtest 02 Not used

Subtest 03 Not used

Subtest 04 Fan on/off

This subtest checks fan operation using the on/off command.

The fan cable is securely connected to the system board. When you execute this subtest, the following message is displayed:

```
*** Fan ON *** : Press [Enter] key?
```

When you press **Enter**, the fan should spin.

```
*** Fan OFF *** : Press [Enter] key?
```

When you press **Enter**, the fan should stop.

Subtest 05 Thermistor check

This subtest reads the thermistor connect check status of the power supply microprocessor, then compares it with the original data. If the data indicates the connector is open or shorted, it displays an error message.

3.5 Memory Test

To execute the Memory Test, select **2** from the DIAGNOSTIC TEST MENU, press **Enter** and follow the directions displayed on the screen. Move the highlight bar to the subtest you want to execute and press **Enter**.

Subtest 01 RAM constant data

This subtest writes a 256-byte unit of constant data to conventional memory (0 to 640 KB). Then reads the new data and compares the result with the original data. The constant data is FFFFh, AAAAh, 5555h, and 0000h.

Subtest 02 RAM address pattern data

This subtest writes address pattern data created by the exclusive-ORing (XORing), to the address segment and address offset in conventional memory program end to 640 KB, then reads the new data and compares the result with the original data.

Subtest 03 RAM refresh

This subtest writes a 256-byte unit of constant data to conventional memory (0 to 640 KB) then reads the new data and compares the result with the original data.

The constant data is AAAAh and 5555h.

NOTE: *There is a short delay between write and read operations, depending on the size of the data.*

Subtest 04 Protected mode

NOTE: *The CONFIG.SYS file must be configured without expanded memory manager programs such as EMM386.EXE, EMM386.SYS or QEMM386.SYS. Also, the HIMEM.SYS must be deleted from the CONFIG.SYS file.*

This subtest writes constant data and address data to extended memory (maximum address 100000h) then reads new data and compares the result with the original data.

The constant data is FFh, AAh, 55h, and 00h.

Subtest 05 Memory module

NOTE: To execute this subtest, an optional memory card must be installed in the computer.

This subtest functions the same as subtest 04, except it is used for testing an optional memory card. Memory module capacity is 8MB, 16MB, and 32MB.

After selecting subtest 05, the following message will appear:

```
Extended memory size
(1:8 MB, 2:16 MB, 3:32 MB)?
```

Select the number that corresponds to the memory card installed in the computer.

Subtest 06 Cache memory

To test the cache memory, a pass-through write-read comparison of '5A' data is run repeatedly to the test area ('7000':'Program' size to '7000':'7FFF' (32 KB)) to check the hit-miss ratio (on/off status) for CPU cache memory. One test takes 3 seconds.

```
Number of misses < Number of hits → OK
Number of misses ≥ Number of hits → Fail
```

3.6 Keyboard Test

To execute the Keyboard Test, select **3** from the DIAGNOSTIC TEST MENU, press **Enter** and follow the directions displayed on the screen. The Keyboard test contains four subtests that test the keyboard, PS/2 mouse, and AccuPoint actions. Move the highlight bar to the subtest you want to execute and press **Enter**.

Subtest 01 Pressed key display

***NOTE:** The **Num Lock** and the **Overlay** mode must be off to execute this subtest.*

When you execute this subtest, the keyboard layout is drawn on the display as shown below. When any key is pressed, the corresponding key on the screen changes to an “*” character. Holding a key down enables the auto-repeat function which causes the key’s display character to blink.

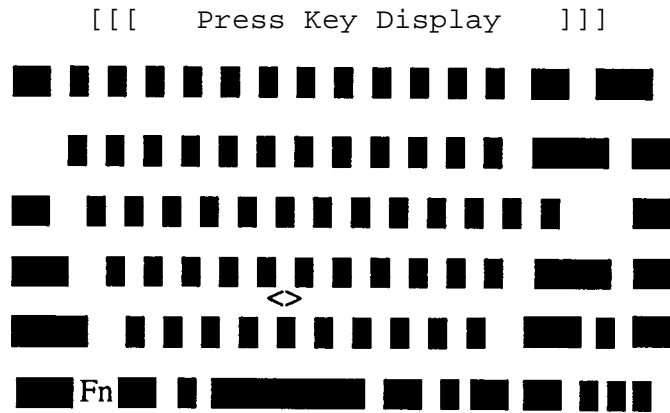

If test OK, Press [Del] [Enter] Key

Subtest 02 Pressed keycode display

When a key is pressed, the scan code, character code, and keytop name are displayed on the screen in the format shown below. The **Ins**, **Caps Lock**, **Num Lock**, **Scroll Lock**, **Alt**, **Ctrl**, **Left Shift**, and **Right Shift** keys are displayed in reverse screen mode when pressed. The scan codes, character codes, and keytop names are shown in Appendix D.

```
KEYBOARD TEST    IN PROGRESS    302000
```

```
          Scan code            =
          Character code       =
          Keytop                =
```

```
  Ins Lock Caps Lock Num Lock    Scroll Lock
  Alt   Ctrl  Left Shift Right Shift
```

```
PRESS [Enter] KEY
```

Subtest 03 PS/2 Mouse connect check

***NOTE:** To execute the PS/2 mouse connect check, a PS/2 mouse must be connected to the computer.*

This subtest checks whether or not a PS/2 mouse is connected.

If this test does not detect an error, it returns to the subtest menu. If this test detects an error, the following message appears:

```
KBD - MOUSE INTERFACE ERROR
```

```
[[ HALT OPERATION ]]
```

```
1: Test end
2: Continue
3: Retry
```

Subtest 04 Pointing Stick

This subtest checks the functions of the pointing stick as shown below.

- A) IPS stick pressure sensing direction and parameter.
- B) IPS switch function check.

This test reports the pointing stick motion response from the IPS and IPS switch by displaying the location parameters. When the stick is pressed towards the upper left, the <POINTING> display changes according to the following illustration. If an IPS switch is pressed, the <BUTTON> display alternates between black and white. Also, the parameters appear on the right side of the display. If two IPS switches are pressed at the same time, the subtest menu is displayed.

***** IPS TEST PROGRAM (V1.00) *****

< POINTING >

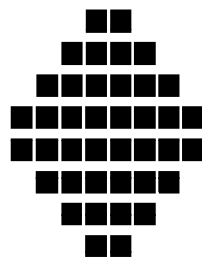

< PARAMETER >

STATUS: 0000h
X-RATE: 0000h
Y-RATE: 0000h

< BUTTON >

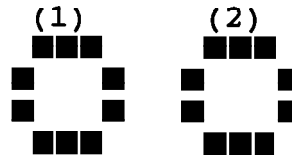

<< PRESS BUTTON1 + BUTTON2 THEN END >>

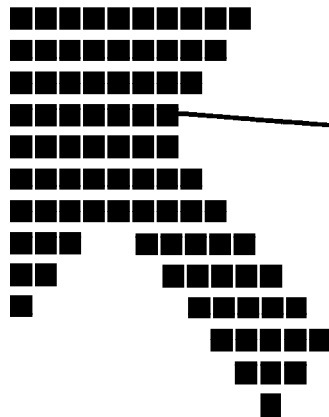

There are eight arrow directions as shown below.

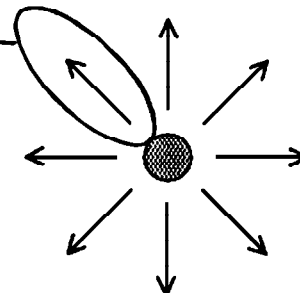

When a button is pressed, the display alternates as shown below.

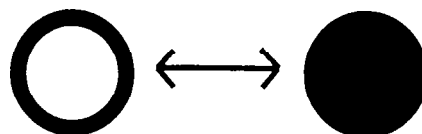

3.7 Display Test

To execute the Display Test, select **4** from the DIAGNOSTIC TEST MENU, press **Enter** and follow the directions displayed on the screen. The Display test contains six subtests that test the display in various modes. Move the highlight bar to the subtest you want to execute and press **Enter**.

Subtest 01 VRAM Read/Write for VGA

This subtest writes constant data AAh and 55h and address data to video RAM (2MB: A0000h-AFFFFh). This data is then read from the video RAM and compared to the original data.

Subtest 02 Gradation for VGA

This subtest displays four colors: red, green, blue, and white from left to right across the screen from black to maximum brightness. The display below appears on the screen when this subtest is executed.

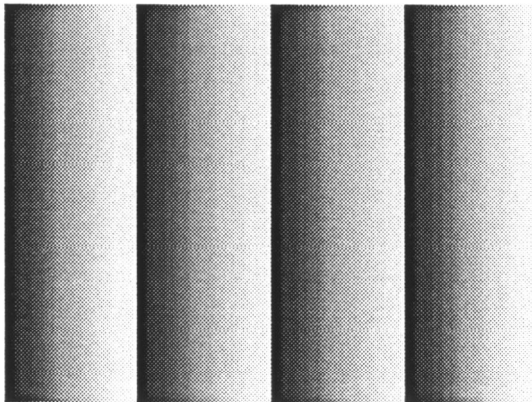

To exit this subtest and return to the DISPLAY TEST menu, press **Ctrl + Break**, then press the **Enter** key.

Subtest 03 Gradation for LCD

This subtest displays eight colors: red, semi-red, green, semi-green, blue, semi-blue, white, and semi-white. Each color is displayed full screen for three seconds.

Subtest 04 Gradation & Mode test for VGA

This subtest displays gradations for each mode. Execute the test, then press **Enter** to change the mode.

LCD type	Mode
TFT	3, 12, 13, 43, 52
DSTN	3, 12, 13, 43

The display below appears on the screen when this subtest is executed.

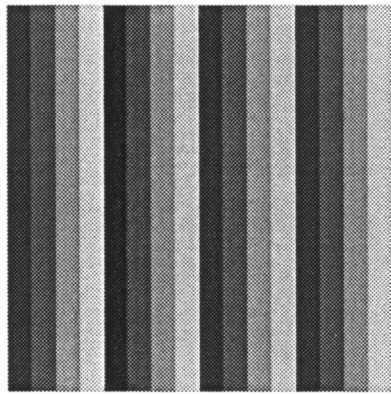

Pressing **Enter** changes the size of the displayed image.

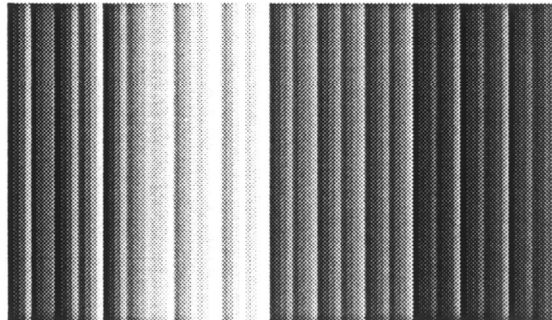

Pressing **Enter** changes the size of the displayed image.

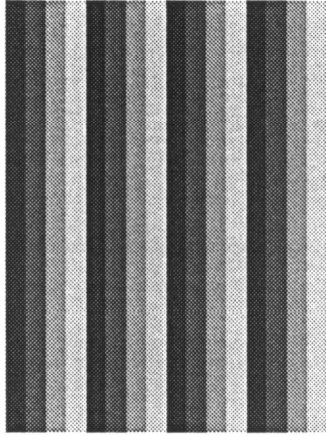

Pressing **Enter** changes the size of the displayed image.

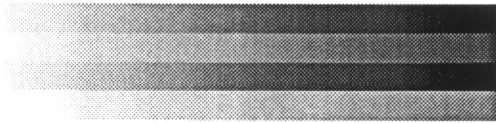

Pressing **Enter** changes the size of the displayed image.

To exit this subtest and return to the DISPLAY TEST menu, press **Ctrl + Break**.

Subtest 05 All dots on /off for LCD

This subtest displays an all-white screen (all dots on) for three seconds then an all-black screen (all dots off) for three seconds. To exit this subtest and return to the DISPLAY TEST menu, press **Ctrl + Break**.

3.8 Floppy Disk Test

***NOTE:** Before running the floppy disk test, prepare a formatted work disk. Remove the Diagnostics Disk and insert a work disk into the FDD. The contents of the floppy disk will be erased.*

To execute the Floppy Disk Test, select **5** from the DIAGNOSTIC TEST MENU, press **Enter** and follow the directions displayed on the screen. The Floppy Disk test contains five subtests that test the FDD. The following messages will appear after selecting the Floppy Disk Test from the DIAGNOSTIC TEST MENU. Answer each question with an appropriate response to execute the test.

1. Select the test drive number of the floppy disk drive to be tested and press **Enter**.

Test drive number select (1:FDD#1,2:FDD#2,0:FDD1&2) ?

2. Select the media type of the floppy disk in the test drive to be tested, and press **Enter**.

Media in drive #X mode (0:2DD,1:2D,2:2D-2HD/2DD,3:2HD) ?

3. Select the track you want the test to start on and press **Enter**. Simply pressing **Enter** sets the start track to zero.

Test start track (Enter:0/dd:00-79) ?

4. The floppy disk test menu will appear after you select the start track number. Select the number of the subtest you want to execute and press **Enter**. The following message will appear during the floppy disk test.

FLOPPY DISK

XXXXXXXX

```
xxxx DIAGNOSTIC TEST VX.XX
[Ctrl]+[Break] ; test end
[Ctrl]+[C] ; key stop
```

Subtest 01 Sequential Read

This subtest performs a Cyclic Redundancy Check (CRC), that continuously reads all the tracks on a floppy disk. The following tracks are read according to the media type in the floppy disk drive:

Double-sided, double-density (2D): Tracks 0 to 39.

Double-sided, double-density, double-track (2DD) and double-sided, high-density, double-track (2HD): Tracks 0 to 79.

The start track is specified when the FDD test is started from the Diagnostic Test Menu. Refer to step 3 at the beginning of this section to set the start track.

Subtest 02 Sequential Read/Write

This subtest continuously writes data pattern B5ADADh to all the specified tracks selected in subtest 01. The data is then read and compared to the original data.

Subtest 03 Random Address/Data

This subtest writes random data to random addresses on all tracks defined in subtest 01. The data is then read and compared to the original data.

Subtest 04 Write Specified Address

This subtest writes specified data to a specified track, head, and address.

Subtest 05 Read Specified Address

This subtest reads data from a specified track, head, and address.

3.9 Printer Test

To execute the Printer Test, select **6** from the DIAGNOSTIC TEST MENU, press **Enter** and follow the directions displayed on the screen. The Printer Test contains three subtests that test the output of the printer connected to the computer.

***NOTE:** An IBM compatible printer must be connected to the system to execute this test.*

The following message will appear when the printer test is selected:

```
channel#1 = XXXXh
channel#2 = XXXXh
channel#3 = XXXXh
Select the channel number (1-3) ?
```

The printer I/O port address is specified by the XXXXh number. The computer supports three printer channels. Select the printer channel number, and press **Enter** to execute the selected subtest.

Subtest 01 Ripple Pattern

This subtest prints characters for codes 20h through 7Eh line-by-line while shifting one character to the left at the beginning of each new line.

```
:"#$%&'()*+,-./0123456789:;<=>?@ABCDEFGHIJKLMNopqrstuvwxyz[\]^_`abcdefghijklmnop
:"#$%&'()*+,-./0123456789:;<=>?@ABCDEFGHIJKLMNopqrstuvwxyz[\]^_`abcdefghijklmnop
:"#$%&'()*+,-./0123456789:;<=>?@ABCDEFGHIJKLMNopqrstuvwxyz[\]^_`abcdefghijklmnopq
#$%&'()*+,-./0123456789:;<=>?@ABCDEFGHIJKLMNopqrstuvwxyz[\]^_`abcdefghijklmnopqr
#$%&'()*+,-./0123456789:;<=>?@ABCDEFGHIJKLMNopqrstuvwxyz[\]^_`abcdefghijklmnopqrs
#$%&'()*+,-./0123456789:;<=>?@ABCDEFGHIJKLMNopqrstuvwxyz[\]^_`abcdefghijklmnopqrst
E'()*+,-./0123456789:;<=>?@ABCDEFGHIJKLMNopqrstuvwxyz[\]^_`abcdefghijklmnopqrstu
'()*+,-./0123456789:;<=>?@ABCDEFGHIJKLMNopqrstuvwxyz[\]^_`abcdefghijklmnopqrstuv
()*+,-./0123456789:;<=>?@ABCDEFGHIJKLMNopqrstuvwxyz[\]^_`abcdefghijklmnopqrstuvw
)++,-./0123456789:;<=>?@ABCDEFGHIJKLMNopqrstuvwxyz[\]^_`abcdefghijklmnopqrstuvwx
*+,-./0123456789:;<=>?@ABCDEFGHIJKLMNopqrstuvwxyz[\]^_`abcdefghijklmnopqrstuvwxy
```

Subtest 02 Function

This subtest is for IBM compatible printers, and tests the following functions:

- Normal print
- Double-width print
- Compressed print
- Emphasized print
- Double-strike print
- All characters print

This subtest prints the various print types shown below:

```
PRINTER TEST
1.   THIS LINE SHOWS NORMAL PRINT.
2.   THIS LINE SHOWS DOUBLE-WIDTH PRINT.
3.   THIS LINE SHOWS COMPRESSED PRINT.
4.   THIS LINE SHOWS EMPHASIZED PRINT.
5.   THIS LINE SHOWS DOUBLE-STRIKE PRINT.
6.   ALL CHARACTERS PRINT
!"#$%&'()*+,-./
0123456789:;<=>?@ABCDEFGHIJKLMN OPQRSTUVWXYZ[\]^_`abcdefghijklmnop
opqrstuvwxyz{|}~
```

Subtest 03 Wraparound

NOTE: To execute this subtest, a printer wraparound connector must be connected to the printer port. The printer wraparound connector (34M741986G01) wiring diagram is described in Appendix F.

This subtest checks the output and bidirectional modes of the data control and status lines through the printer wraparound connector.

3.10 Async Test

To execute the Async Test, select **7** from the DIAGNOSTIC TEST MENU, press **Enter** and follow the directions displayed on the screen. The async test contains eight subtests that test the asynchronous communication functions. Move the highlight bar to the subtest you want to execute and press **Enter**.

Subtests 01 through 08 require the following data format:

Method:	Asynchronous
Speed:	9600BPS (Subtests 01 to 05) 38400BPS (Subtests 06 to 08)
Data:	8 bits and one parity bit (EVEN)
Data pattern:	20h to 7Eh

The following message will appear at the bottom of the screen when subtests 01, 03, 04, 06, 07 and 08 are selected:

```
Channel#1 = XXXXh
Channel#2 = XXXXh
Channel#3 = XXXXh
Select the Channel number (1/2/3)
```

The serial I/O port address is specified by the XXXXh number. Select the serial port channel number, and press **Enter** to start the subtest.

Subtest 01 Wraparound (board)

***NOTE:** To execute this subtest an RS-232-C wraparound connector (34M741621G01) must be connected to the RS-232-C port. The RS-232-C wraparound connector wiring diagram is described in Appendix F.*

This subtest checks the data send/receive function through the wraparound connector.

Subtest 02 Board (#1) <=> board (#2)

***NOTE:** To execute this subtest an RS-232-C cable (9-pin to 9-pin) must be connected to boards 1 and 2. The RS-232-C direct cable wiring diagram is described in Appendix F.*

This subtest checks the data send/receive function through the RS-232-C direct cable.

Subtest 03 Point to point (Send)

NOTE: To execute this subtest, two machines must be connected with an RS-232-C direct cable. One machine should be set as “send”(subtest 03) and the other set as “receive” (subtest 04). The wiring diagram for the RS-232-C direct cable is described in Appendix F.

This subtest sends 20h through 7Eh data to the receive side, then receives the sent data and compares it to the original data.

Subtest 04 Point to point (Receive)

This subtest is used with subtest 03 described above. This subtest receives the data from the send side, then sends the received data.

Subtest 05 Interrupt Test

This subtest checks the Interrupt Request Level of IRQ 4, 3, and 5 from the send side.

Subtest 06 Infra_red Wrap_around test

NOTE: Before conducting subtests 06 to 09, you must execute SIRDRV.COM to enable the infrared communication port.

This subtest checks the data send/receive function through the SIR port.

Subtest 07 Infra_red Transmit mode

NOTE: To execute subtests 07 and 08, each computer must have access to the other computer’s infrared port.

This subtest sends 20h through 7Eh data to the receive side, then receives the sent data and compares it to the original data through the SIR port.

Subtest 08 Infra_red Receive mode

This subtest is used with subtest 07 described above. This subtest receives the data from the send side, then sends the received data through the SIR port.

3.11 Hard Disk Test

To execute the Hard Disk Test, select **8** from the DIAGNOSTIC TEST MENU, press **Enter** and follow the directions displayed on the screen. The hard disk test contains ten subtests that test the hard disk drive functions.

***NOTE:** The contents of the hard disk will be erased when subtest 02, 03, 04, 05, 06, 08, 09, or 10 is executed. Before running the test, transfer the contents of the hard disk to floppy disk.*

- 1. If MS-DOS 6.22/Windows for Workgroups is selected, use the Master Diskette Creator (MDC) utility in the Toshiba Utility folder to back up the preinstalled software. After backing up the preinstalled software, use the BACKUP command in the Toshiba Companion Utility to back up the entire disk, including the user's files.*
- 2. If Windows95 is selected, check to see if the Microsoft Create System Disks Tools (MSCSD.EXE) still exists in the System Tools Folder. (This tool can be used only once.) If it exists, use it to back up the preinstalled software, then use the Backup utility in the System Tools folder to back up the entire disk, including the user's files.*

Refer to the operating system instructions for each operating system.

1. When you select the hard disk test from the DIAGNOSTIC TEST MENU, the following message will appear:

```
Test drive number select (1:HDD#1,2:HDD#2,0:HDD1&2) ?
```

2. Select the hard disk drive number to be tested and press **Enter**. The following message will appear:

```
HDC F/W error retry (1:yes,2:no) ?
```

3. Select **1** or **2** and press **Enter**. The following message will appear:

```
Data compare error dump (1:no,2:yes) ?
```

This message is used to select the retry operation when the hard disk controller detects an error.

4. Select **1** or **2** and press **Enter**. The following message will appear:

```
Detail status display (1:no,2:yes) ?
```

This message is used to select the error dump operation when a data compare error is detected.

5. The HDD status is described in section 3.18. Select **1** or **2** and press **Enter**. The Hard Disk Test message will appear after you respond to the Detail Status prompt.
6. Select the number of the subtest you want to execute and press **Enter**. The following message will appear during each subtest.

```
HARD DISK TEST      XXXXXXXX

SUB-TEST : XX
PASS COUNT: XXXXX  ERROR COUNT: XXXXX
WRITE DATA: XX  READ DATA : XX
ADDRESS : XXXXXX STATUS : XXX
```

The first three digits of the ADDRESS indicate which cylinder is being tested, the fourth digit indicates the head and the last two digits indicate the sector.

The first digit of the STATUS number indicates the drive being tested and the last two digits indicate the error status code as explained in Table 3-2.

Subtest 01 Sequential Read

This subtest is a sequential reading of all the tracks on the HDD starting at track 0. When all the tracks on the HDD have been read, the test starts at the maximum track and reads the tracks on the HDD sequentially back to track 0.

Subtest 02 Address Uniqueness

This subtest writes unique address data to each sector of the HDD track-by-track. The data written to each sector is then read and compared with the original data. There are three ways the HDD can be read:

- Forward sequential
- Reverse sequential
- Random

Subtest 03 Random Address/Data

This subtest writes random data to random addresses on the HDD cylinder, head and sector. This data is then read and compared to the original data.

Subtest 04 Cross Talk & Peak Shift

This subtest writes eight types of worst pattern data (shown below) to a cylinder, then reads the data while moving from cylinder to cylinder.

Worst pattern data	Cylinder
'B5ADAD'	0 cylinder
'4A5252'	1 cylinder
'EB6DB6'	2 cylinder
'149249'	3 cylinder
'63B63B'	4 cylinder
'9C49C4'	5 cylinder
'2DB6DB'	6 cylinder
'D24924'	7 cylinder

Subtest 05 Write/read/compare (CE)

This subtest writes B5ADADh worst pattern data to the CE cylinder on the HDD, then reads the data from the CE cylinder and compares it with the original data.

Subtest 06 Write specified address

This subtest writes specified data to a specified cylinder and head on the HDD.

Subtest 07 Read specified address

This subtest reads data which has been written to a specified cylinder and head on the HDD.

Subtest 08 ECC circuit

This subtest checks the Error Check and Correction (ECC) circuit functions of the specified cylinder and head on the HDD.

Subtest 09 Sequential write

This subtest writes specified 2-byte data to all of the cylinders on the HDD.

Subtest 10 W-R-C specified address

This subtest writes data to a specified cylinder and head on the HDD, then reads the data and compares it to the original data.

3.12 Real Timer Test

To execute the Real Timer Test, select **9** from the DIAGNOSTIC TEST MENU, press **Enter** and follow the directions on the screen. The real timer test contains three subtests that test the computer's real timer functions. Move the highlight bar to the subtest you want to execute and press **Enter**.

Subtest 01 Real Time

A new date and time can be input during this subtest. To execute the real time subtest follow these steps:

1. Select subtest 01 and the following message will appear:

```
Current date : XX-XX-XXXX
Current time : XX:XX:XX
```

```
Enter new date:
```

```
PRESS [ENTER] KEY TO EXIT TEST
```

2. If the current date is not correct, input the correct date at the "Enter new date" prompt and press **Enter**. The following prompt will appear:

```
Enter new time :
```

3. If the current time is not correct, input the correct time in 24-hour format. Pressing **Enter** toggles between the time and the date. To exit, press **Ctrl + Break**.

Subtest 02 Backup Memory

This subtest performs the following backup memory check:

```
Writes 1-bit of "on" data to address 01h through 80h
Writes 1-bit of "off" data to address 0Eh through 80h
Writes the data pattern AAh and 55h to the RTC 114-byte memory
(address 0Eh to 7Fh)
```

The subtest reads and compares this data with the original data.

To exit, press **Ctrl + Break**.

Subtest 03 Real Time Carry

CAUTION: *When this subtest is executed, the current date and time are erased.*

This subtest checks the real time clock increments, making sure the date and time are displayed in the following format:

```
Current date   : 12-31-1995
Current time   : 23:59:58
```

Pressing **Enter** displays the following:

```
Current date   : 01-01-1996
Current time   : 00:00:00
```

```
PRESS [Enter] KEY TO EXIT TEST
```

Press **Ctrl + Break** to exit.

3.13 NDP Test

To execute the NDP test, select **10** from the DIAGNOSTICS TEST MENU, press **Enter** and follow the directions on the screen. The NDP test contains one subtest that tests the computer's NDP functions.

Subtest 01 NDP

This test checks the following functions of the coprocessor:

- Control word
- Status word
- Bus
- Addition
- Multiplication

Press **Ctrl + Break** to exit.

3.14 Expansion Test

To execute the expansion test, select **11** from the DIAGNOSTICS TEST MENU, press **Enter** and follow the directions on the screen. The expansion test contains two subtests.

NOTE: To execute this subtest, the PC card wraparound connector is required.

Subtest 01 PCMCIA wraparound (Internal)

This test checks the following signal line of the PC card slot:

- Address line
- REG#, CE#1, CE#2 line
- Data line
- Speaker line
- Wait line
- BSY#, BVD1 line

This subtest is executed in the following order:

Sub#	Address	Good	Bad	Contents
01	00001 00001	nn nn	xx xx	Address line REG#, CE#1, CE#2 nn=A0, 90, 80, 00
02	00002	ww	rr	Data line ww=write data, rr=read data
03	00003	—	—	Speaker line
04	00004	40, 80	xx	Wait line (40<xx<80)
05	00005	nn	xx	Other lines (BSY#, BVD1) nn=21, 00

Subtest 02 PCMCIA wraparound (External)

This test checks the signal lines of the Enhanced Port Replicator PC card slots:

Procedures for conducting this test are the same as for subtest 01 PCMCIA wrap-around (Internal) described above.

3.15 Sound Test

To execute the sound test, select **12** from the DIAGNOSTICS TEST MENU, press **Enter** and follow the directions on the screen. The sound test contains six subtests that test the computer's sound functions.

NOTE: To execute this subtest, the internal microphone and internal headphone (or internal speaker) are required.

WARNING: The system is capable of producing high volume sound, so when you use the headphones be careful to set the volume low and adjust it as necessary. Using the headphones at full volume could damage your ears.

Subtest 01 CODEC (REC/PLAY)

This subtest tests the functions of the Codec (ES688) A/D, D/A converter. At the same time, it tests the microphone terminals and Headphone terminals. When you execute this subtest the following message is displayed:

```
[Quick REC & PLAY for ES488/688]
Press any key to *** REC ***
```

After pressing a key, start recording, and immediately play the sound. (It takes three seconds.)

Subtest 02 FM Synthesizer

This subtest tests the OPL# (YMF262) functions. Connect the headphone and check the scale of the right and left sides. Also, check the sound adjustment volume.

Subtest 03 SINE-wave playback

This subtest expands the sine-wave data table to 64KB and creates sine-wave data. The play data is transferred between DMA and CODEC, and plays the sound. (It is a long beep.) Also, use the oscilloscope to observe the sine-wave form.

Subtest 04 Joystick

To execute this subtest, the Enhanced Port Replicator and a joystick are required. For minimum sampling data, turn the stick to the upper left, and press the A or B button. For maximum sampling data, turn the stick to the lower right and press the A or B button (it must be a different button than the one used for minimum sampling data). If two sampling data are the same, an error occurs.

Subtest 05 Joystick/MIDI wraparound

Conduct a wraparound test on the joystick/MIDI port.

Subtest 06 Codec (Line In/Out)

Load the file ESS688L.COM. Connect a sound source such as a CD player or stereo to the line-in port. Next, connect an output device such as an amplifier for the internal speaker or a radio/cassette player to the line-out port.

After making the connections, a dialogue box will be displayed. Press **Enter** to play a recorded sound. About three seconds after the recorded sound is played, the dialogue box will be displayed again.

NOTE: *The Enhanced Port Replicator must be connected to conduct the line-out test.*

3.16 CD-ROM Test

To execute the CD-ROM test, select **13** from the DIAGNOSTICS TEST MENU, press **Enter** and follow the directions on the screen. The CD-ROM test contains four subtests that test the computer's CD-ROM functions.

NOTE: First make sure the CD-ROM driver (*CDROMDRV.COM*) is installed and insert the test media CD (*Toshiba-EMI Test Disk TDY-03*).

Subtest 01 Sequential Read

This subtest is a sequential reading of one block unit (2K bytes) of all the logical addresses.

Subtest 02 Read Specified Address

This subtest reads one-block data from a specified address.

Subtest 03 Random Address/Data

This subtest reads one-block data and multi-block data from random addresses 200 times.

Subtest 04 Playback Music

NOTE: The Toshiba-EMI Test Disk TDY-03 cannot be used for Subtest 04. For this test, use an ordinary music CD.

This subtest reads track data from a specified track and plays the sound.

3.17 Error Code and Error Status Names

Table 3-2 lists the error codes and error status names for the Diagnostic Test.

Table 3-2 Error codes and error status names

Device name	Error code	Error status name
(Common)	FF	Data Compare Error
System	01	ROM Checksum Error
Memory	01	Parity Error
	02	Protected Mode Not Changed
	14	Memory Read/Write Error
	DD	Cache Memory Error
Keyboard	01	Mouse Interface Error
	02	IPS Interface Error
	03	Interface Error
	04	Retransmit Error
	05	Mouse Handler Not Supported
	06	PS/2 Mouse & IPS Not Supported
FDD	01	Bad Command
	02	Address Mark Not Found
	03	Write Protected
	04	Record Not Found
	06	Media Removed
	08	DMA Overrun Error
	09	DMA Boundary Error
	10	CRC Error
	20	FDC Error
	40	Seek Error
	60	FDD Error
	80	Time Out Error
	EE	Write Buffer Error
Printer	01	Time Out
	08	Fault
	10	Select Line
	20	Out Of Paper
	40	Power Off
	80	Busy Line
ASYNC	01	DSR On Time Out
	02	CTS On Time Out
	04	RX-READY Time Out

Table 3-2 Error codes and error status names (Continued)

Device name	Error code	Error status name
ASYNC (cont.)	08	TX-BUFFER Full Time Out
	10	Parity Error
	20	Framing Error
	40	Overrun Error
	80	Line Status Error
	88	Modem Status Error
HDD	01	Bad Command Error
	02	Address Mark Not Found
	04	Record Not Found
	05	HDC Not Reset Error
	07	Drive Not Initialized
	08	HDC Overrun (DRQ)
	09	DMA Boundary Error
	0A	Bad Sector
	0B	Bad Track Error
	10	ECC Error
	11	ECC Recover Enabled
	20	HDC Error
	40	Seek Error
	80	Time Out Error
	AA	Drive Not Ready
	BB	Undefined Error
CC	Write Fault	
E0	Status Error	
EE	Access Time Out Error	
NDP	01	No Co-Processor
	02	Control Word Error
	03	Status Word Error
	04	Bus Error
	05	Addition Error
	06	Multiply Error
Expansion	C1	Address Line Error
	C2	REG# Line Error
	C3	CE#1 Line Error
	C4	CE#2 Line Error
	C5	DATA Line Error
	C6	WAIT Line Error
	C7	BSY# Line Error
	C8	BVD1 Line Error
	CD	No PCMCIA

Table 3-2 Error codes and error status names (Continued)

Device name	Error code	Error status name
CD-ROM	01	Bad Command
	02	Illegal Length
	03	Unit Attention
	04	Media Change Request
	05	Media Detected
	06	Additional Sense
	09	Boundary Error
	11	Corrected Data Error
	20	Drive Not Ready
	40	Seek Error
	80	Time Out
	90	Reset Error
	B0	Address Error

3.18 Hard Disk Test Detail Status

When an error occurs in the hard disk test, the following message is displayed:

```
HDC status = XXXXXXXX
```

Detailed information about the hard disk test error is displayed on the screen by an eight-digit number. The first four digits represent the hard disk controller (HDC) error status number and the last four digits are not used.

The hard disk controller error status is composed of 2 bytes; the first byte displays the contents of the HDC status register in hexadecimal form and the second byte displays the HDC error register.

The contents of the HDC status register and error register are listed in Tables 3-3 and 3-4.

Table 3-3 Hard disk controller status register contents

Bit	Name	Description
7	BSY (Busy)	"0" --- HDC is ready. "1" --- HDC is busy.
6	DRDY (Drive ready)	"0" --- Hard disk drive is not ready to accept any command. "1" --- Hard disk drive is ready to accept any command.
5	DWF (Drive write fault)	"0" --- DWF error is not detected. "1" --- Write fault condition occurs.
4	DSC (Drive seek complete)	"0" --- The hard disk drive heads are not settled over a track. "1" --- The hard disk drive heads are settled over a track.
3	DRQ (Data request)	"0" --- Drive is not ready for data transfer. "1" --- Drive is ready for data transfer.
2	CORR (Corrected data)	"0" --- Not used "1" --- Correctable data error is corrected.
1	IDX (Index)	"0" --- Not used "1" --- Index is sensed.
0	ERR (Error)	"0" --- Normal "1" --- The previous command was terminated with some error.

Table 3-4 Error register contents

Bit	Name	Description
7	BBK1 (Bad block mark)	"0" Not used "1" A bad block mark is detected.
6	UNC (Uncorrectable)	"0" There is no uncorrectable data error. "1" Uncorrectable data error has been detected.
5	—	Not used
4	IDNF (Identification)	"0" Not used "1" There was no ID field in the requested sector.
3	—	Not used
2	ABRT (Abort)	"0" Not used "1" Illegal command error or a drive status error occurs.
1	TK00 (Track 0)	"0" The hard disk has found track 0 during a recalibrate command. "1" The hard disk could not find track 0 during a recalibrate command.
0	—	Not used

3.19 Hard Disk Format

This command executes hard disk formatting. There are two types of hard-disk formatting:

- Low-level (physical) formatting
- MS-DOS (logical) formatting

This hard disk format function performs a low-level format of the hard disk and executes the following hard disk formats and check:

1. All track FORMAT
2. Good track FORMAT
3. Bad track FORMAT
4. Bad track CHECK

NOTES: *The contents of the hard disk will be erased when subtest 02, 03, 04, 05, 06, 08, 09, or 10 is executed. Before running the test, transfer the contents of the hard disk to floppy disk.*

1. *If MS-DOS 6.22/Windows for Workgroups is selected, use the Master Diskette Creator (MDC) utility in the Toshiba Utility folder to back up the preinstalled software. After backing up the preinstalled software, use the BACKUP command in the Toshiba Companion Utility to back up the entire disk, including the user's files.*
2. *If Windows 95 is selected, check to see if the Microsoft Create System Disks Tools (MSCSD.EXE) still exists in the System Tools Folder. (This tool can be used only once.) If it exists, use it to back up the preinstalled software, then use the Backup utility in the System Tools folder to back up the entire disk, including the user's files.*

Refer to the operating system instructions for more information.

3.19.1 Function Description

1. All track FORMAT

This option performs a low-level format of all the tracks on the hard disk as shown in Table 3-5 below:

NOTE: Before executing the all track format option, check for bad tracks using the Bad Track CHECK option or display a list of bad tracks on the HDD.

Table 3-5 Hard disk formatting sequence

Items	Toshiba MK1301MAV	IBM DMCA-21440	Seagate ST91350AG
Formatted capacity (byte)	1,358,880,768	1,445,068,800	1,350,107,136
Number of disks	3	2	3
Logical heads	16	16	16
Logical cylinders	2,633	2,800	2,616
Bytes per sector	512	512	512
Rotation speed (rpm)	4,200	4,000	4,500

2. Good track FORMAT

This option formats a specified cylinder and track as a good track. If a good track is formatted as a bad track, use this option to change the track to a good track.

3. Bad track FORMAT

This option formats a specified cylinder and track as a bad track. If a bad track is detected, use this option to label it as a bad track.

4. Bad track CHECK

This option searches the hard disk for bad tracks by reading data to all the tracks on the hard disk. A list of bad tracks is displayed when the program is complete. If an error other than a bad track is detected, the program is automatically terminated.

3.19.2 Operations

***NOTE:** After the HDD has been formatted, execute the Toshiba MS-DOS FDISK command to partition the HDD. Next, execute the Toshiba MS-DOS FORMAT command. Refer to the Toshiba MS-DOS manual for more information about using these commands.*

Selecting **2** and pressing **Enter** in the DIAGNOSTIC MENU displays the following messages:

```
DIAGNOSTICS - HARD DISK FORMAT : VX.XX

1 - All track FORMAT
2 - Good track FORMAT
3 - Bad track FORMAT
4 - Bad track CHECK
9 - Go to TEST MENU

↑↓→← : Select items, Enter: Finish, Esc: Exit
```

1. All track FORMAT

Pressing **1** selects All track FORMAT, which lets you format the entire disk.

```
[All track FORMAT]

Drive      :      #1 = HDD          #2 = Non
Cylinder   :      XXXX
Head       :      XX
Sector     :      XX

<<< Model name =      >>>
```

The following selections also appear, in succession, at the bottom of the screen:

```
Drive number select (1:#1,2:#2) ?
```

(a) Select a drive number and press **Enter**. The following message will appear:

```
Interleave number (1/1 ~ 8) ?
```

(b) Select an interleave number, 1 ~ 8 and press **Enter**. Pressing only **Enter** selects 1.

(c) Bad track register

Next, the Bad Track register prompt will appear as shown below. Enter the cylinder and head numbers of bad tracks and press **Enter**. Note that if there are no bad tracks, pressing **Enter** alone is the same as executing All Track Format described in item (d) below.

```
[ WARNING : Current DISK data will be
           completely destroyed ]
```

```
Press Bad cylinder number (dddd)] key ?
Press Bad head number (dd)] key ?
```

Enter the cylinder and head number in the format above in decimal notation. Repeat for each bad track you want to format.

After entering the bad tracks, press **Enter** to execute the format.

(d) All track format

All tracks are formatted as good tracks except those registered as bad tracks in item (c) above or those identified as bad tracks in track verification described in item (e) below.

(e) Track verification

A check is made of all tracks and if an ECC error, ECC-correctable-data error, or record-not-found error is detected at a track, that track is automatically formatted as a bad track.

2. Good track FORMAT

If a good track has been erroneously formatted as a bad track, you can use this subtest to reformat the track as a good track. To format a track as a good track, enter the number for drive, interleave, cylinder, and head as indicated in the screen prompt shown below.

```
Drive number select (1:#1, 2:#2) ?
Interleave number (1 / 1 - 8) ?
  Press [Cylinder number (dddd)] ?
  Press [Head number (dd)] ?
```

Press **Enter** to return to the Hard Disk Format menu.

3. Bad track FORMAT

To format a track as a bad track, enter the number for drive, interleave, cylinder, and head as indicated in the screen prompt shown below.

```
Drive number select (1:#1, 2:#2) ?  
Interleave number (1 / 1 - 8) ?  
    Press [Cylinder number (dddd)] ?  
    Press [Head number (dd)] ?
```

Press **Enter** to return to the Hard Disk Format menu.

4. Bad track CHECK

This subtest reads the entire disk and displays a list of bad tracks. The test is terminated in case of a bad track check error. To initiate the subtest enter the drive number at the prompt shown below.

```
Drive number select (1:#1, 2:#2) ?
```

Bad tracks will be displayed in the format shown below.

```
[[cylinder, head = 0123 03]]
```

Press **Enter** to return to the Hard Disk Format menu.

3.20 Head Cleaning

3.20.1 Function Description

This function cleans the heads in the FDD by executing a series of head load/seek and read operations. A cleaning kit is necessary to perform this program.

3.20.2 Operations

1. Selecting test **4** from the DIAGNOSTIC MENU and pressing **Enter** displays the following messages:

```
DIAGNOSTICS - FLOPPY DISK HEAD CLEANING : VX.XX
```

```
Mount cleaning disk(s) on drive(s).
```

```
Press any key when ready.
```

2. Remove the Diagnostics Disk from the FDD, then insert the cleaning disk and press **Enter**.
3. When the "cleaning start" message appears, the FDD head cleaning has begun.
4. The display automatically returns to the DIAGNOSTIC MENU when the program is completed.

2. The error information displayed on the screen can be manipulated by the following number keys:

The **1** key scrolls the display to the next page.

The **2** key scrolls the display to the previous page.

The **3** key returns to the Diagnostic Menu.

The **4** key erases all error log information in RAM.

The **5** key outputs the error log information to a printer.

The **6** key reads the log information from a floppy disk.

The **7** key writes the log information to a floppy disk.

3. In the case of “error retry OK,” a capital “R” will be placed at the beginning of the error status. However, it is not added to the error count.

3.22 Running Test

3.22.1 Function Description

This function automatically executes the following tests in sequence:

1. System test (subtest number 01)
2. Memory test (subtest number 01, 02, 04, 06)
3. Display test (subtest number 01, 03, 05)
4. FDD test (subtest number 02)
5. HDD test (subtest number 01, 05)
6. Real timer test (subtest number 02)
7. Printer test (subtest number 03) if selected
8. Async test (subtest number 01) if selected

The system automatically detects the number of floppy disk drives connected to the computer for the FDD test.

3.22.2 Operations

***NOTE:** Do not forget to load a work disk in the FDD. If a work disk is not loaded, an error will be generated during the FDD testing.*

1. Remove the diagnostics disk from the floppy disk drive and insert the work disk.
2. Selecting **6** from the Diagnostic Menu and pressing **Enter** displays the following message:

```
Printer wrap around test (Y/N) ?
```

Selecting **Y (yes)** executes the printer wraparound test. A printer wraparound connector must be connected to the parallel port of the computer to properly execute this test.

3. Select **Y** or **N** and press **Enter**. The following message will appear:

```
Serial #A wrap around test (Y/N) ?
```

Selecting **Y (yes)** executes the ASYNC wraparound test. An RS-232-C wrap-around connector must be connected to the serial port of the computer to properly execute this test.

4. Select **Yes** or **No** and press **Enter**. The following message will appear :

```
Mount the work disk(s) on the drive(s),  
then press [Enter] key.  
[Warning : The contents of the disk(s),  
will be destroyed.]
```

5. This program is executed continuously. To terminate the program, press **Ctrl + Break**.

3.23 Floppy Disk Drive Utilities

3.23.1 Function Description

This function formats the FDD, copies the floppy disk and displays the dump list for both the FDD and HDD.

1. FORMAT

***NOTE:** This program is only for testing a floppy disk drive. The option is different from the Toshiba MS-DOS FORMAT command.*

This program can format a 5.25-inch or 3.5-inch floppy disk as follows:

- (a) 2D: Double-sided, double-density, 48/67.5 TPI, MFM mode, 512 bytes, 9 sectors/track.
- (b) 2DD: Double-sided, double-density, double-track, 96/135 TPI, MFM mode, 512 bytes, 9 sectors/track.
- (c) 2HD: Double-sided, high-density, double-track, 96/135 TPI, MFM mode, 512 bytes, 18 sectors/track.

2. COPY

This program copies data from a source floppy disk to a target floppy disk.

3. DUMP

This program displays the contents of the floppy disk and the designated sectors of the hard disk on the display.

3.23.2 Operations

1. Selecting **7** from the DIAGNOSTIC MENU and pressing **Enter** displays the following message:

```
[ FDD UTILITIES ]  
1 - FORMAT  
2 - COPY  
3 - DUMP  
9 - EXIT TO DIAGNOSTICS MENU
```

2. FORMAT program

- (a) Selecting FORMAT displays the following message:

```
DIAGNOSTICS - FLOPPY DISK FORMAT : VX.XX  
Drive number select (1:A, 2:B) ?
```

- (b) Select a drive number to display the following message:

```
Type select (0:2DD-2DD,1:2D-2D,2:2D-2HD,3:2HD-2HD) ?
```

- (c) Select a media/drive type number and press **Enter**. A message similar to the one below will be displayed:

```
Warning : Disk data will be destroyed.
```

```
Insert work disk into drive A:
```

```
Press any key when ready.
```

- (d) Remove the Diagnostics Disk from the FDD, insert the work disk, and press any key.

The following message will be displayed when the FDD format is executed:

```
[ FDD TYPE ] : TRACK = XXX
```

```
[ FDD TYPE ] : HEAD = X
```

```
[ FDD TYPE ] : SECTOR = XX
```

```
Format start
```

```
[[track, head = XXX X]]
```

After the floppy disk is formatted, the following message will appear:

```
Format complete
```

```
Another format (1:Yes/2:No) ?
```

- (e) Typing **1** displays the message from step (c) above. Typing **2** returns the test to the DIAGNOSTIC MENU.

3. COPY program

- (a) When COPY is selected, the following message appears:

```
FLOPPY DISK FORMAT & COPY : VX.XX
```

```
Type select (0:2DD-2DD,1:2D-2D,2:2D-2HD,3:2HD-2HD) ?
```

- (b) Selecting a media/drive type number will display a message similar to the one below:

```
Insert source disk into drive A:
```

```
Press any key when ready.
```

- (c) Remove the Diagnostics Disk from the FDD, insert the source disk and press any key. The following message will appear, indicating the program has started.

```
[ FDD TYPE ] : TRACK = XXX
```

```
[ FDD TYPE ] : HEAD = X
```

```
[ FDD TYPE ] : SECTOR = XX
```

```
Copy start
```

```
[[ track,head = XXX X ]]
```

- (d) Remove the source disk from the FDD, insert a formatted work disk and press any key. The [[track, head = XXX X]] message will appear and start copying to the target disk. When the amount of data is too large to be copied in one operation, the message from step (b) is displayed again. After the floppy disk has been copied, the following message will appear:

```
Copy complete
Another copy (1:Yes/2:No) ?
```

- (e) To copy another disk, type **1** and the message from step (a) will be displayed again. Entering **2** returns the test program to the DIAGNOSTIC MENU.

4. DUMP program

- (a) When dump is selected, the following message appears:

```
DIAGNOSTICS-HARD DISK & FLOPPY DISK DUMP : VX.XX
Drive type select (1:FDD, 2:HDD) ?
```

- (b) Select a drive type. If **1** is selected in step (a), the following message displays:

```
Select drive number (1:A, 2:B) ?
```

Select an FDD drive number. The display will go to step (c).

If **2** is selected, the following message displays:

```
Select drive number (1:C, 2:D) ?
```

After selecting the HDD, the display will go to step (f).

- (c) The following message will be displayed:

```
Format type select (1:2DD, 2:2D, 3:2HD) ?
```

- (d) Select a format type and the following message will appear:

```
Insert source disk into drive A:
Press any key when ready.
```

- (e) Insert a source disk, press any key, and the following message will appear:

```
— Max. address —
[Track ] = 0079
[ Head ] = 01
[Sector] = 09

Track number ??
```

- (f) Set the track number you want to dump. Then, the system will access the disk and dump a list.

3.24 System Configuration

3.24.1 Function Description

The System Configuration program contains the following configuration information for the computer:

1. BIOS ROM version
2. Boot ROM version
3. KBC version
4. PS microprocessor version
5. Base memory size
6. The number of floppy disk drives
7. The number of ASYNC ports
8. The number of hard disk drives
9. The number of printer ports
10. Extended memory size
11. The number of math co-processors
12. CPU clock
13. ID number of the Enhanced Port Replicator

3.24.2 Operations

Selecting **8** from the DIAGNOSTIC MENU and pressing **Enter** displays the following system configuration:

SYSTEM CONFIGURATION :

```
* - BIOS ROM VERSION = VX.XX      * - ? CARD DOCK ROTARY SWITCH
* - BOOT ROM VERSION = VX.XX
* - KBC VERSION       = VX.XX
* - PS MICOM VERSION = VX.XX
* - 639KB MEMORY
* - 1 FLOPPY DISK DRIVE(S)
* - 1 ASYNC ADAPTER
* - 1 HARD DISK DRIVE(S)
* - 1 PRINTER ADAPTER
* - XXXMB + XXXXKB EXTENDED MEMORY
* - 1 MATH CO-PROCESSOR
* - CPU CLOCK          = 120MHz
```

Press [Enter] Key

Press **Enter** to return to the DIAGNOSTIC MENU.

3.25 SETUP

3.25.1 Function Description

This program displays the current system setup information as listed below:

1. Memory
 - (a) Total
 - (b) Base
 - (c) Extended Memory
 - (d) Shadow BIOS ROM

2. Display
 - (a) Display Adapter
 - (b) LCD Display Mode
 - (c) VGA Segment Address
 - (d) LCD Display Colors
 - (e) Power On Display
 - (f) Text Mode Stretch

3. Hard Disk
 - (a) HDD Mode

4. Password

5. I/O Ports
 - (a) Serial Port
 - (b) Infrared Port
 - (c) Parallel Port
 - (d) Sound System

6. Others
 - (a) Power-up Mode
 - (b) CPU Cache
 - (c) Battery Save Mode
 - (d) Alarm Volume
 - (e) System Beep
 - (f) Panel Power On/Off
 - (g) Alarm Power On
 - (h) Keyboard
 - (i) Pointing Devices
 - (j) Boot Priority

3.25.2 Accessing the SETUP Program

Selecting **0** from the DIAGNOSTICS MENU and pressing **Enter** displays the following:

SYSTEM SETUP		BIOS version = x.xx	
MEMORY		I/O PORTS	
Total	= 16384 KB	Serial Port	= COM1(3F8H/IRQ4)
Base	= 640 KB	Infrared Port	= Not Used
Extended	= 15552 KB	Parallel Port	= LPT1(378H/IRQ7/CH3)
Shadow BIOS ROM	= 192 KB	Sound System	= Address/IRQ/DMA
DISPLAY		OTHERS	
Display Adapter	= VGA compatible	Power-up Mode	= Resume
LCD Display Mode	= Color	CPU Cache	= Enabled
VGA Segment Address	= E400H	Battery Save Mode	= Full Power
LCD Display Colors	= 16M Colors	Alarm Volume	= High
Power On Display	= Internal/External	System Beep	= Enabled
Text Mode Stretch	= Enabled	Panel Power On/Off	= Disabled
HARD DISK		Alarm Power On	= Disabled
HDD Mode	= Enhanced IDE (Normal)	Keyboard	= Layout/Fn
POWER ON PASSWORD		Pointing Devices	= Auto-selected
Not Registered		Boot Priority	= FDD→HDD

↑↓→← : Select items, Space, BkSp : Change values

Esc: Exit without saving, Home: Set default values, End: Save changes and Exit

NOTES:

1. The Panel Power On/Off item appears only when the computer is in Resume mode.
2. The 430CDS "LCD Display Colors" options are 222k and 4096 colors.

3.25.3 Moving Within the SETUP Menu and Changing Values

1. Press → and ← to move between the two columns. Press ↑ and ↓ to move between items in a column.
2. Press either the **space bar** or **BkSp** to change the value.

3.25.4 Accepting Changes and Exiting the SETUP Window

1. Press **End** to accept the changes you made.

If the changed item does not require the system to reboot, the following message is displayed:

Are you sure? (Y/N)

If the changed item requires the system to reboot, the following message is displayed:

Are you sure? (Y/N)

The changes you made will cause the system to reboot.

2. To make other changes, press **N**. Repeat the steps above.
3. To accept the changes, press **Y**.

NOTE: You can press *Esc* to quit at any time without saving changes. *SETUP* asks you to confirm that you don't want to save your changes.

3.25.5 The Factory Preset Configuration

When you access *SETUP*, the current configuration is displayed.

1. To show the factory preset configuration, press **Home**.
2. To accept the default settings, press **End** and then press **Y**.

NOTE: When you execute the default setting, the following settings are not changed:

HDD Mode

Password

Sound System: I/O Address, Interrupt Level, DMA

Write Policy

3.25.6 SETUP Options

The *SETUP* screen is divided into functionally related groups. This section describes each group and its options.

1. Memory

This option lists the computer's memory allocation.

- (a) Total

Displays the total amount of memory installed and is automatically calculated by the computer. You cannot change this value.

- (b) Base

Displays the amount of base (conventional) memory, **640 KB**, and is automatically calculated by the computer. You cannot change this value.

- (c) Extended

Displays the amount of extended memory the computer has available. You cannot change this value.

(d) Shadow BIOS ROM

Displays 192 KB of RAM, which is reserved for the Shadow BIOS ROM. The value cannot be changed.

2. Display

This option configures the computer's display.

(a) Display Adapter

This field displays the internal controller for the VGA internal display. Only **VGA compatible** is displayed. You cannot change it.

(b) LCD Display Mode

The LCD displays text in 80 characters by 25 lines and graphics in 800 by 600 pixels for either **Color** or **Monochrome** mode. Use this option to set the computer's display mode to **Color** or **Monochrome**.

Color Selects color mode. (Default)

Monochrome Selects monochrome mode. Some software is displayed better in monochrome mode.

(c) VGA Segment Address

Use this option to set the VGA segment address from the following option:

C000H, E000H, E400H (Default)

NOTE: In the DOS environment, if you choose either *E400H* or *C000H*, the Pop-up window is not displayed when you press the **Fn+F2** or **Fn+F3** hotkeys. However, the corresponding functions of the keys work.

(d) LCD Display Colors

Used to select the color palette of the internal display when the LCD mode is set to **Color**.

TFT display

256K colors Displays 16M colors. (This value cannot be changed.)

DSTN display

222K colors Displays 256 colors out of 226,981 colors.

4096 colors Displays 256 colors out of 4096 colors.

NOTE: If the **DSTN** screen flickers with an **LCD Display Colors** setting of **222K Colors**, select **4096 Colors**.

(e) Power On Display

This option is used to select the display when booting up.

Internal/External Selects an external CRT if one is connected, otherwise it selects the internal LCD. (Default)

Simultaneous Selects both the internal LCD and the external CRT for simultaneous display.

NOTE: When starting the computer in Resume mode, the last configuration is remembered. If data does not appear on the display you are using after starting in Resume mode, press **Fn+F5**.

Pressing **Fn+F5** changes the display setting as follows: internal LCD to simultaneous to external CRT.

(f) Text Mode Stretch

Text mode stretch enables a larger display area of 800 x 600 pixels in text mode. Disabling this function reduces the resolution to the standard 800 x 600 pixels.

Enabled Enables the text mode stretch feature. (Default)

Disabled Disables the text mode stretch feature.

3. Hard Disk

Use this item to select the hard disk mode.

Enhanced IDE Select this mode when using MS-DOS, Windows or OS/2. (Default)
(Normal)

Standard IDE Select this mode when using Novell NetWare or UNIX. When this mode is selected, up to 504MB is logically available even though the disk's capacity is larger than 504MB.

NOTE: Formats for Enhanced IDE and Standard IDE are different, so if you change the setting, you will have to reformat the hard disk for the appropriate setting.

4. Password

This option allows you to set or reset the user password for power on and instant security.

Registered The user password has been registered.

Not registered The user password has not been registered.

For details on setting the user password, refer to the 430 User's Manual.

5. I/O Ports

This option controls settings for serial and parallel ports and the sound system.

(a) Serial Port

This option allows you to set the COM level, *COM1* to *COM4*, for the serial port. The serial port interrupt request level (IRQ) and I/O port base address for each COM level is shown below:

COM level	Interrupt level	I/O address
COM1	4	3F8h (Serial port default)
COM2	3	2F8h
COM3	4	3E8h
	5	3E8h
	7	3E8h
COM4	3	2E8h
	5	2E8h
	7	2E8h
Not used		(Disables port)

NOTE: Do not assign the same interrupt request level and I/O address to the serial port and infrared port.

(b) Infrared Port

This option allows you to set the COM level for the infrared port.

The infrared port interrupt request level (IRQ) and I/O port base address for each COM level is shown below.

COM level	Interrupt level	I/O address
COM1	4	3F8h
COM2	3	2F8h
COM3	4	3E8h
	5	3E8h
	7	3E8h
COM4	3	2E8h
	5	2E8h
	7	2E8h
Not used		(Disables port) (Infrared port default)

NOTE: If the setting for the infrared port is the same as that for the serial port, the serial port is automatically set to disabled.

(c) Parallel Port

This option sets the interrupt request level (IRQ) and I/O port base address for the parallel port. The options are shown below:

LPT setting	Interrupt level	I/O address
LPT1	7	378h (Parallel port default)
LPT2	5	278h
LPT3	7	3BCh
Not used		(Disables port)

When you select one of the above options, except for *Not used*, a subwindow similar to the one below appears to let you set the parallel port mode and DMA channel.

Mode

Use this option to set the parallel port mode from among the following settings:

ECP (Default), Std.Bi-Directional

DMA channel

When the parallel port mode is set to ECP, the DMA channel can also be set from among the following settings:

Ch1, Ch2, Ch3 (Default)

(d) Sound system

This item allows you to enable or disable the sound card ports.

Address/IRQ/DMA Enables port (Default)

Disabled Disables port

When *Address/IRQ/DMA* is selected, a subwindow similar to the one below appears to let you set the *I/O address*, *Interrupt level*, and *DMA channel* for the sound card.

SOUND SYSTEM		
I.O Address	=	0220H
Interrupt Level	=	IRQ10
DMA	=	Channel

I/O address

Use this option to set the I/O address from among the following settings:

0220h (Default), 0230h, 0240h, 0250h

Interrupt level

This option sets the interrupt level for the sound system. The available settings are:

IRQ5, IRQ7, IRQ9, IRQ10 (Default)

NOTE: *Sound Blaster compatible software uses IRQ7 as the default. If you use such software, try to change the software setting to IRQ10. If you cannot change the software setting, change the hardware setting to IRQ7.*

DMA (direct memory access) channel

Use this option to set the DMA channel. The available settings are:

Channel 0, Channel 1 (Default), Channel 3

6. Others

Whether or not you need to configure the computer with these options depends primarily on the kind of software or peripherals you use.

(a) Power-up Modes

This option lets you choose between AutoResume and boot mode. You can also set this option using hotkeys. AutoResume is effective with either the internal LCD or with an external monitor.

Boot Turns on boot mode. (Default)

Resume Turns on the AutoResume feature.

(b) CPU Cache

Use this feature to enable or disable the CPU cache.

Enabled Enables the CPU cache. (Default)

Disabled Disables the CPU cache.

When enabled is selected, a subwindow similar to the one below is displayed to let you select the cache write policy. The options for this setting are **Write-back** (default) and **Write-through**.

Option	
Write Policy	= Write-back

Write-back policy provides better system performance, because main memory is accessed only when necessary to update the cache contents with changes in main memory. Write-through policy accesses main memory every time data is handled by the processor.

(c) Battery Save Mode

This option is used to select **Full Power** or **Low Power** or **User Setting** of the **BATTERY SAVE OPTION**.

Full Power The following shows full power settings.

BATTERY SAVE OPTIONS	
Processing Speed	= High
CPU Sleep Mode	= Enabled
Display Auto Off	= Disabled (430CDS) 30 Min. (430CDT)
HDD Auto Off	= 30 Min.
System Auto Off	= Disabled
LCD Brightness	= Bright
Cooling Method	= Performance

Low Power The following shows low power settings.

BATTERY SAVE OPTIONS	
Processing Speed	= Low
CPU Sleep Mode	= Enabled
Display Auto Off	= 03 Min.
HDD Auto Off	= 03 Min.
System Auto Off	= 30 Min.
LCD Brightness	= Semi-Bright
Cooling Method	= Quiet

NOTE: In boot mode, the System Auto Off message does not appear.

User Setting This option allows you to set the battery save parameters on the sub-window, **BATTERY SAVE OPTIONS**. When you select this option, the automatic setting feature (Full Power or Low Power) is disabled and the user-preferred parameters become effective. The default setting in the sub-windows depends on the **Battery Save Mode: Low Power (Long Life) or Full Power (Normal Life)**. For details, see *Battery Save Options* below.

(1) Battery Save Options

The following set of options can be selected in the sub-menu of *User Setting*, which is one of the **Battery Save Mode** options.

Processing Speed

This feature changes the CPU processing speed.

High CPU operates at 120 MHz. (Default)

Low CPU operates at half speed.

CPU Sleep Mode

Use this option to enable or disable the CPU sleep function.

Enabled Enables sleep mode.

Disabled Disables sleep mode.

Display Auto Off

Use this option to disable or set the duration of the display automatic power off function. This function causes the computer to turn the LCD panel illumination off if you make no entry for the set period of time.

Disabled Disables display automatic power off.

xx Min. Automatically turns off power to the LCD panel illumination if the panel is not used for the duration set. The duration **xx** can be set to 1, 3, 5, 10, 15, 20, or 30 minutes.

HDD Auto Off

Use this option to disable or set the duration of the HDD automatic power off function.

- Disabled* Disables display automatic power off.
- xx Min.* Automatically turns off power to the hard disk drive if it is not used for the duration set. The duration **xx** can be set to 1, 3, 5, 10, 15, 20, or 30 minutes. (Default is 30 minutes.)

System Auto Off

Use this option to enable or disable the system automatic off function in Resume mode when you are working in DOS. In Boot mode, it is disabled and not displayed.

- Disabled* Disables system automatic power off.
- xx Min.* Automatically turns off power to the system if it is not used for the duration set. The duration **xx** can be set to 10, 20, 30, 40, 50, or 60 minutes.

LCD Brightness

Use this option to set the level of LCD brightness.

- Bright* Full brightness for maximum visibility.
- Semi-Bright* Less than full brightness for saving power.

Cooling method

- Performance* If the CPU becomes too hot, the fan is turned on automatically. The CPU processing speed does not change. When the CPU temperature falls to a normal range, the fan is turned off.
- Quiet* Fan operation is disabled. If the CPU becomes too hot the processing speed is lowered. When the CPU temperature falls to a normal range, the processing speed is increased.

(d) Alarm Volume

Disables or sets the volume level of the alarm. Setting this option to off disables the computer's sound function for alarms. This option can also be set by hotkeys.

<i>Off</i>	Disables the alarm.
<i>Low</i>	Sets the alarm volume to low.
<i>Medium</i>	Sets the alarm volume to medium.
<i>High</i>	Sets the alarm volume to high. (Default)

When Alarm Volume is selected, the subwindow below is displayed to let you enable or disable certain functions.

ALARM VOLUME OPTIONS		
Low BATTERY Alarm	=	Enabled
Panel Close Alarm	=	Enabled

<i>Enabled</i>	Enables the feature. (Default)
<i>Disabled</i>	Disables the feature.

(e) System Beep

Use this feature to enable or disable the system beep.

Enabled Enables the feature. (Default)

Disabled Disables the feature.

(f) Panel Power On/Off

Allows you to automatically turn your computer on or off by opening or closing the display panel. If this feature is enabled when the computer is in Resume mode, the system is automatically powered off when the display panel is closed and powered on when the panel is opened. This option does not appear when the computer is in boot mode.

Enabled Enables the feature.

Disabled Disables the feature. (Default)

NOTE: Do not remove the AC cable and battery pack at the same time when you use this feature. If you do so, data saved by AutoResume will be lost. You must also reset this option.

(g) Alarm Power On

Lets you set the time for the system to turn on automatically. For example, if you are expecting to receive a modem transmission at a time when you are away or asleep, you can set this option to the time of the transmission. This option does not automatically turn off the system. This feature operates in either Resume or boot mode.

00:00:00 Sets the power on time (24-hour clock).

Disabled Disables the alarm.

NOTE: Do not remove the AC cable and battery pack at the same time when you use this feature. If you do so, the setting will be lost. You must reset this option when you restore power.

(h) Keyboard

This option lets you change the keyboard layout and set the Fn key equivalent when you are using an external keyboard. Selecting this option displays the following subwindow.

Keyboard		
Int. Keyboard key layout	=	Normal
Ext. Keyboard "FN" key equivalent	=	Disabled

Int. Keyboard layout

This option lets you select the arrangement of the **Caps Lock**, **Ctrl** and **Alt** keys according to the following illustrations:

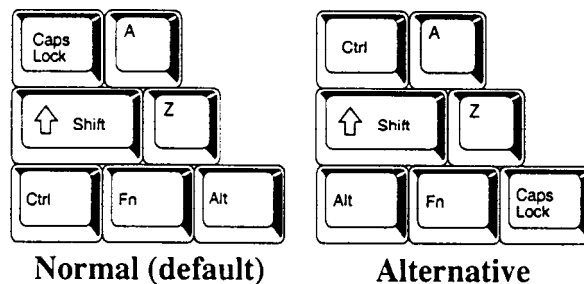

Ext. Keyboard **Fn** key equivalent

Use this option to set a key combination on an external keyboard to emulate the **Fn** key on the computer's internal keyboard. Setting an **Fn** key equivalent will enable you to use "Hotkeys" by pressing the set combination in place of the **Fn** key.

<i>Disabled</i>	No Fn key equivalent. (Default)	
<i>Fn Equivalent</i>	Left Ctrl +	Left Alt*
	Right Ctrl +	Right Alt*
	Left Alt +	Left Shift*
	Right Alt +	Right Shift
	Left Alt +	Caps Lock

** If these selections are made, you cannot warm boot the system by pressing **Ctrl + Alt + Del**.*

(i) Pointing Devices

Enables or disables the AccuPoint.

Auto selected The AccuPoint is disabled when a PS/2 mouse is connected, otherwise the AccuPoint is enabled. (Default)

Simultaneous If a PS/2 mouse is connected, both the AccuPoint and the external mouse are enabled.

(j) Boot Priority

Use this option to select the disk drive priority for boot up.

FDD HDD The computer looks for bootable files first on the FDD and next on the HDD. (Default)

HDD FDD The computer looks for bootable files first on the HDD and next on the FDD.

You can reverse the order by holding down the **F10** key while the computer is booting. This procedure alternates the setup setting.

4.1 General

This section explains how to disassemble the computer and replace Field Replaceable Units (FRUs). It may not be necessary to remove all the FRUs in order to replace one. The chart below is a guide to which FRUs need to be removed in order to remove others. Always start by removing the battery pack, then follow the lines on the chart to determine which FRU you must remove next in order to repair the one you think is causing the computer to operate improperly.

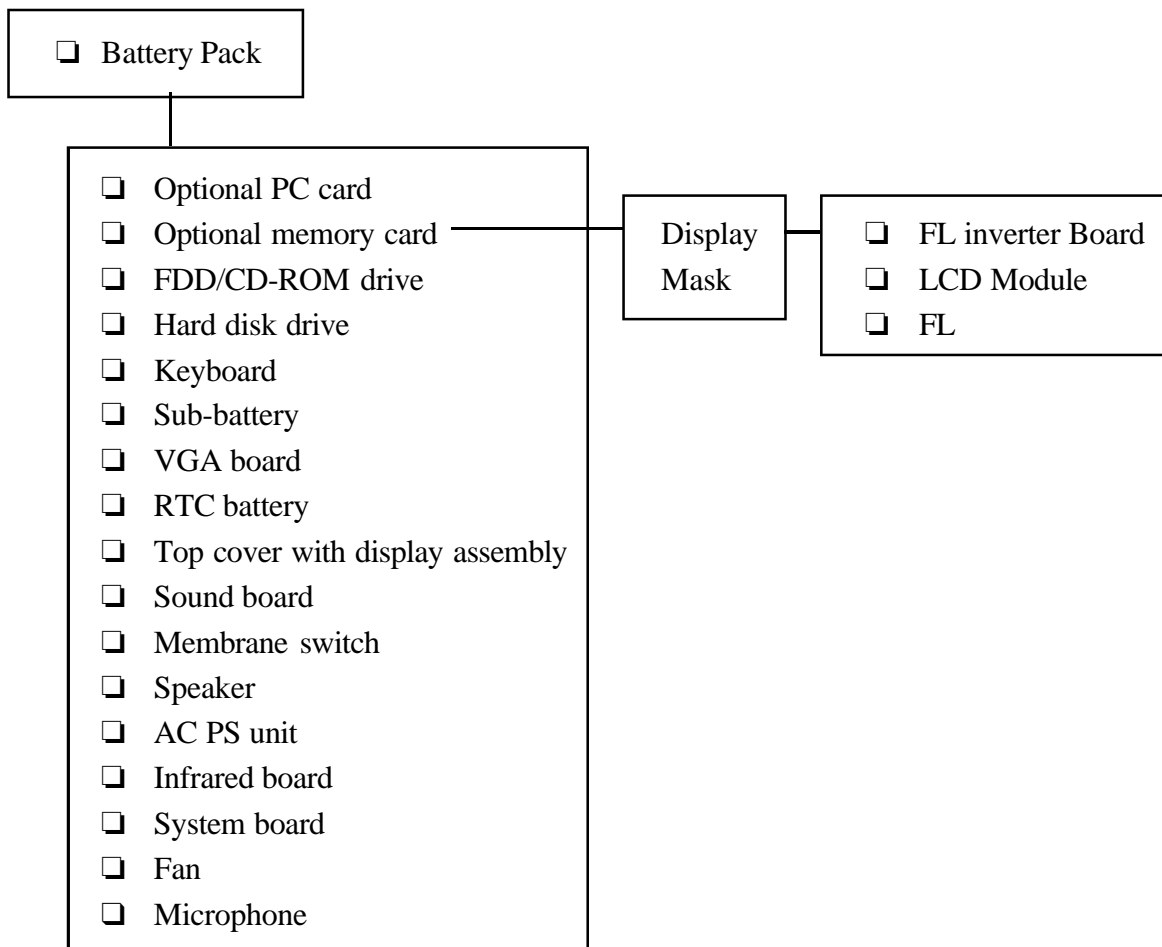

Safety Precautions

Before you begin disassembly, read the following safety precautions and observe them carefully as you work.

- DANGER:**
1. Always use the lithium ion battery pack or backup battery that is authorized by Toshiba or compatible with the unit. Since other battery packs have different specifications, they may be incompatible with the unit, and may burst or explode. Heating or disassembling the battery pack could cause leakage of alkaline solution. Throwing the battery pack into a fire could cause the battery pack to explode.
 2. The power supply, FL inverter, and other components carry high voltages. To avoid the risk of electric shock when you need to turn on the power of a partially disassembled computer to check its operation, be very careful not to touch connectors or components. Also, do not disassemble individual components during first-level maintenance.

WARNING: To avoid the risk of electric shock or other injury:

1. Always turn the power off and disconnect the AC power cord from the power source.
2. Remove any metal jewelry or accessories such as necklaces, bracelets, or rings. Batteries in the computer retain electrical charge so there is danger of electrical shock even when the computer is disconnected from an AC power source.
3. Never work with wet or damp hands.
4. The computer contains many sharp edges and corners, so be careful not to injure yourself.
5. Make sure that all replacement components meet the specifications for the computer and that all cables and connectors are securely fastened.

CAUTION: To avoid damage to the computer:

1. When you change a component, be sure the replacement component meets the required specifications.
2. Metal objects such as screws or paper clips which fall into the unit can cause short-circuit, fire, or other internal damage.
3. When assembling the computer make sure you use the correct screws to secure the various pieces in place. Screw sizes are listed in the corresponding figure. Make sure all screws are securely fastened. Loose screws can cause short circuits, resulting in heat, smoke, or fire.
4. Before removing an FRU or other component, make sure all cables to the component have been disconnected.
5. If you use AC power, be sure to use the cable that came with the computer or one recommended by Toshiba.

Before You Begin

Look over the procedures in this section before you begin disassembling the computer. Familiarize yourself with the disassembly and reassembly steps. Begin each procedure by removing the AC cord and the battery pack as instructed in section 4.2, *Battery Pack*.

1. Do not disassemble the computer unless it is operating abnormally.
2. Use only the correct and approved tools.
3. Make sure the working environment is free from the following elements whether you are using or storing the computer:
 - Dust and contaminants
 - Static electricity
 - Extreme heat, cold, and humidity
4. Make sure the FRU you are replacing is causing the abnormal operation by performing the necessary diagnostics tests described in this manual.
5. Do not perform any unnecessary operations and use only the described procedures for disassembling and installing FRUs in the computer.
6. After removing parts from the computer, place them in a safe place away from the computer so they will not be damaged and will not interfere with your work.
7. You will remove and replace many screws when you disassemble the computer. When you remove screws, make sure they are placed in a safe place and are identified with the correct parts.
8. When assembling the computer make sure you use the correct screws to secure the various pieces in place. Screw sizes are listed in the corresponding figures.
9. The computer contains many sharp edges and corners, so be careful not to injure yourself.
10. After you have replaced an FRU, make sure the computer is functioning properly by performing the appropriate test on the FRU you have fixed or replaced.

Disassembly Procedures

The computer has three basic types of cable connectors:

- Pressure Plate Connectors
- Normal Pin Connectors
- Flexible Cable Connectors

To disconnect a Pressure Plate connector, lift up the tabs on either side of the plastic pressure plate and slide the cable out of the connector. To connect the cable to a Pressure Plate connector, make sure the pressure plate is fully lifted and slide the cable into the connector. Secure the cable in place by pushing the sides of the pressure plate down so the plate is flush with the sides of the connector. Gently pull on the cable to make sure the cable is secure. If you pull out the connector, connect it again making sure the pressure plate is fully lifted when you insert the cable.

Standard pin and flexible cable connectors are used with all other cables. These connectors can be connected and disconnected by simply pulling them apart or pushing them together.

Assembly Procedures

After you have disassembled the computer and fixed or repaired the problem that was causing the computer to operate abnormally, you will need to reassemble the computer. While assembling the computer, remember the following general points:

- Take your time, making sure you follow the instructions closely. Most problems arise when you hurry to assemble the computer.
- Make sure all cables and connectors are securely fastened.
- Before securing the FRU or other parts, make sure that no cables will be pinched by screws or the FRU.
- Check that all latches are closed securely in place.
- Make sure all the correct screws are used to secure all FRUs. Using the wrong screw can damage either the threads on the screw or the head of the screw and may prevent proper seating of an FRU.

After installing an FRU in the computer confirm that the FRU and the computer are functioning properly.

Tools and Equipment

The use of ElectroStatic Discharge (ESD) equipment is very important for your safety and the safety of those around you. Proper use of these devices will increase the success rate of your repairs and lower the cost for damaged or destroyed parts. The following equipment is necessary to disassemble and reassemble the computer:

- One M2 Phillips screwdriver to remove and replace screws.
- Tweezers, to lift out screws that you cannot grasp with your fingers.
- ESD mats for the floor and the table you are working on.
- An ESD wrist strap or heel grounder.
- Anti-static carpeting or flooring.
- Air ionizers in highly static sensitive areas.

Screw Tightening Torque

When you fasten screws, be sure to follow the torque list below. Overtightening can damage components and screws; undertightening can result in electrical shorts or other damage if screws or components come loose.

- M2 0.22 N·m (2.2 kgf·cm)
- M2.5 0.36 N·m (3.5 kgf·cm)
- FDD 0.22 N·m (2.2 kgf·cm)
- HDD 0.3 N·m (3.1 kgf·cm) or less

4.2 Battery Pack

Removing the Battery Pack

To remove the battery pack, follow the steps below and refer to Figures 4-1 and 4-2.

1. Turn off the power to the computer. Disconnect the AC power cord and all external cables connected to the computer.
2. Turn the computer over.
3. Push the **battery cover lock** to release the **battery cover**.
4. Push the cover forward until it stops (about one centimeter or half an inch).

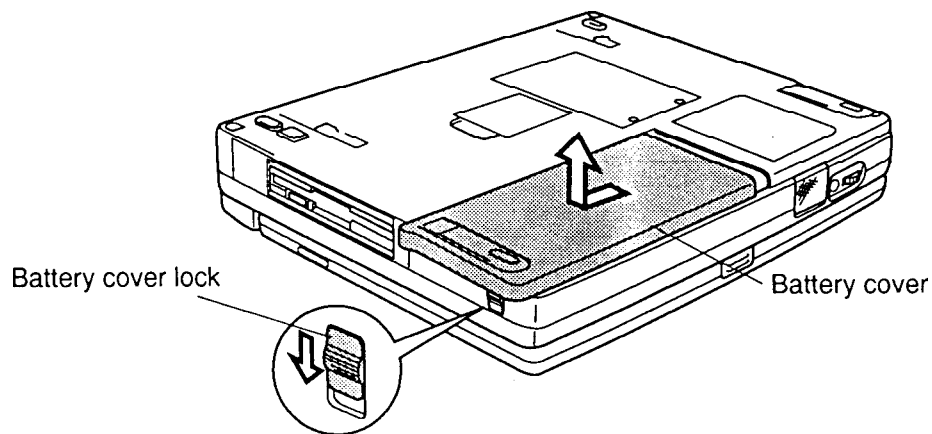

Figure 4-1 Removing the battery pack cover

5. Lift off the cover.
6. Pull back the battery latch and lift out the **battery pack**.

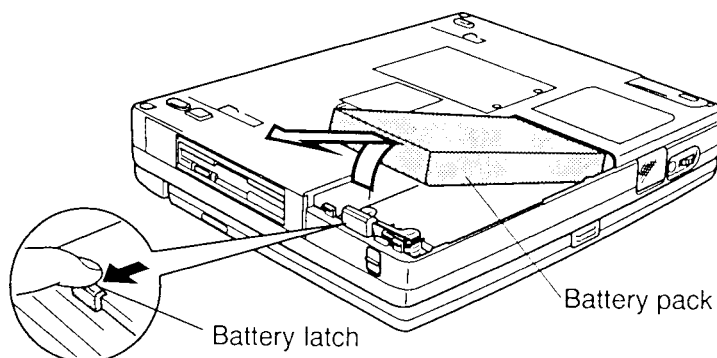

Figure 4-2 Removing the battery pack

NOTE: For environmental reasons, do not throw away a spent battery pack. Please return spent battery packs to your Toshiba dealer.

Installing the Battery Pack

To install the battery pack, follow the steps below and refer to Figures 4-1 to 4-3.

WARNING: The battery is a lithium ion battery and should be replaced only by your dealer or by a Toshiba service representative. The battery can explode if not properly replaced, used, handled or disposed of. Dispose of the battery as required by local ordinances or regulations. Use only batteries recommended by Toshiba as replacements.

1. Turn off the power to the computer. Disconnect the AC power cord and all external cables connected to the computer.
2. Carefully insert the new or recharged **battery pack**.
3. Replace the **battery cover** and push it closed. Be sure the **battery latch** is securely closed.
4. Push the **battery cover lock** to secure the cover.

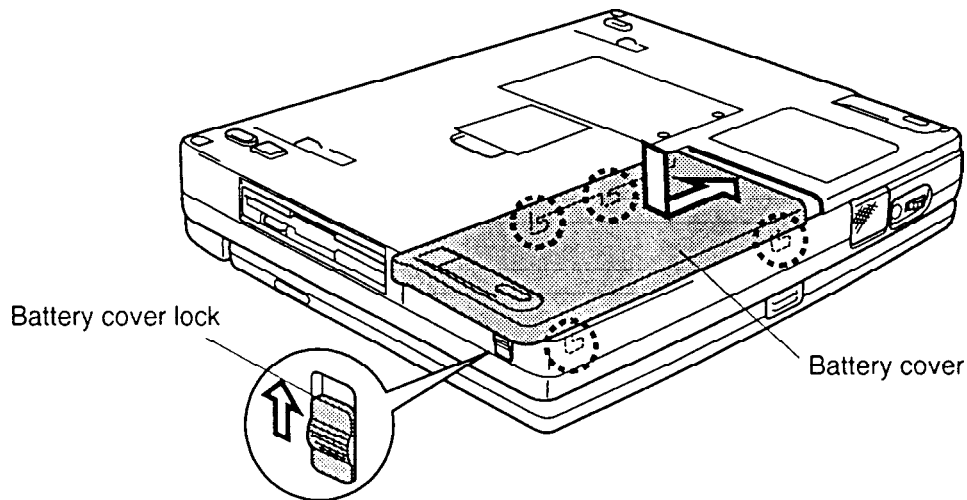

Figure 4-3 Installing the battery pack cover

4.3 Optional PC Card

Removing an Optional PC Card

To remove an optional PC card make sure the computer is in boot mode then follow the steps below and refer to Figure 4-4.

1. Turn off the power to the computer. Disconnect the AC power cord and all external cables connected to the computer.
2. Remove the battery pack as described in Section 4.2.
3. Pull out the **eject button** and press it (the top button for the top card and the bottom button for the bottom card). The card will pop out slightly for removal.

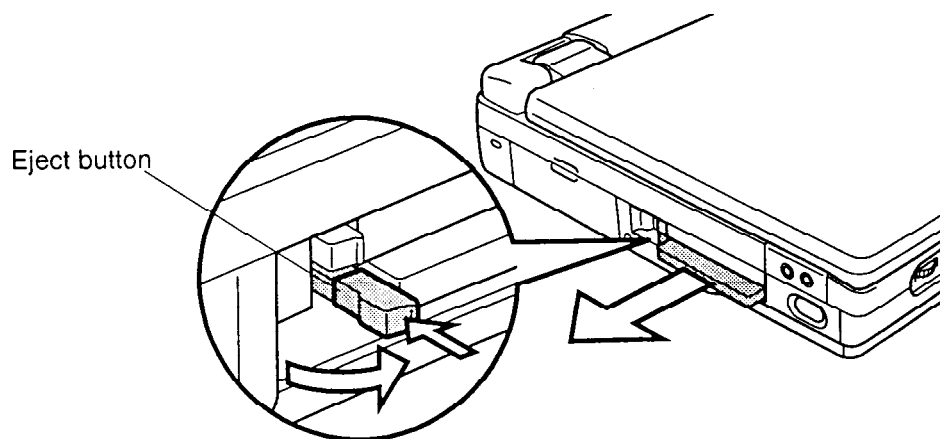

Figure 4-4 Removing the PC card

Installing an Optional PC Card

To install an optional PC card, follow the steps below and refer to Figure 4-5.

NOTE: Before you install the PC card, make sure the computer is in boot mode.

1. Turn off the power to the computer. Disconnect the AC power cord and all external cables connected to the computer.
2. A pair of flaps protects the PC slot. Insert the PC card through these flaps as shown in Figure 4-5.

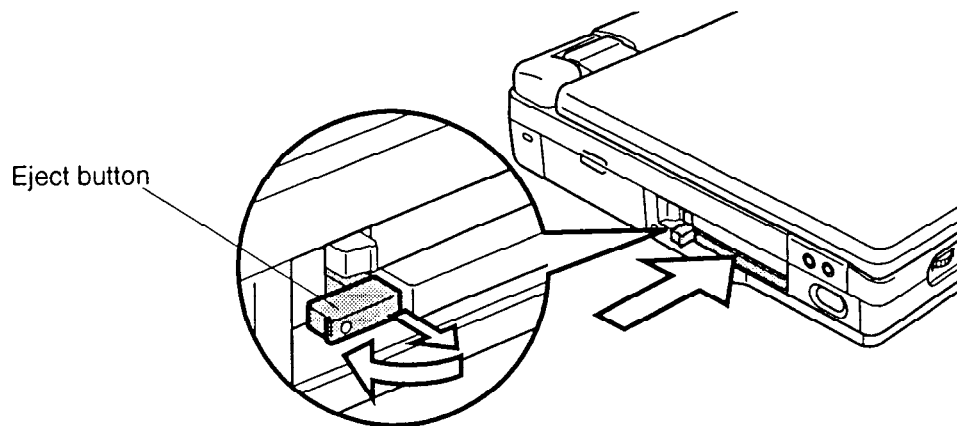

Figure 4-5 Installing the PC card

3. When the card is almost fully seated, you will feel some resistance. Press gently to assure a firm connection, but do not force the card into position.
4. When the card is fully seated, an **eject button** will pop out: the top button for the top connector and the bottom button for the bottom connector.
5. Pull the eject button out slightly and bend it to lock the card.
6. Install the battery pack as described in Section 4.2.

4.4 Optional Memory Module

Removing an Optional Memory Module

To remove an optional memory module, make sure the computer is in boot mode then follow the steps below and refer to Figures 4-6 and 4-7.

1. Turn off the power to the computer. Disconnect the AC power cord and all external cables connected to the computer.
2. Remove the battery pack and Optional PC card as described in Sections 4.2 and 4.3.
3. Turn the computer upside down.
4. Remove **two silver M2x4 screws** securing the **memory module socket cover**.
5. Slide your fingernail or a thin object under the cover and remove it.

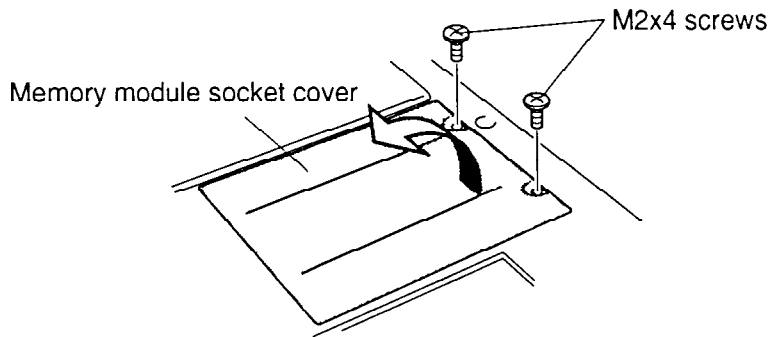

Figure 4-6 Removing the memory module socket cover

6. Remove **two M2x4 screws** securing the module to a brace at the center of the module.

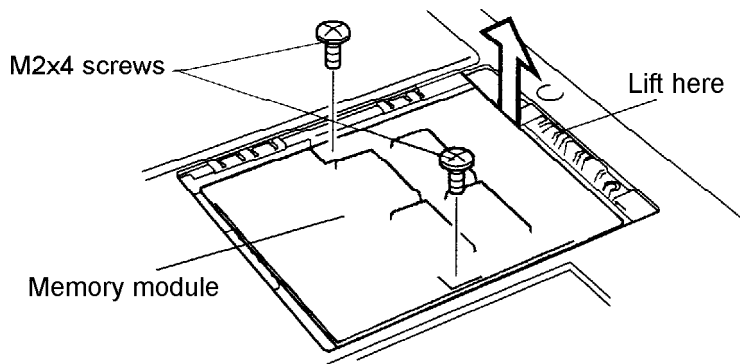

Figure 4-7 Removing the memory module

7. Insert a thin object and lift up to disengage the connector, then grasp the module by the edges and remove it. Some models may have a plastic tab. If so, simply pull up on the tab to disengage the connector.

Installing an Optional Memory Module

To install an optional memory module, make sure the computer is in boot mode then follow the steps below and refer to Figures 4-8 back to 4-6.

1. Position the connector on the bottom of the **module** over the corresponding connector on the computer (align the holes on the side of the module over the screw holes on the brace).

NOTE: Do not touch the connectors on the memory module or on the computer. Debris on the connectors may cause memory access problems.

2. Place your fingers above the connector and press firmly but gently to assure a solid connection. The module should be seated level.
3. Secure the module to the brace with **two M2x4 screws**.

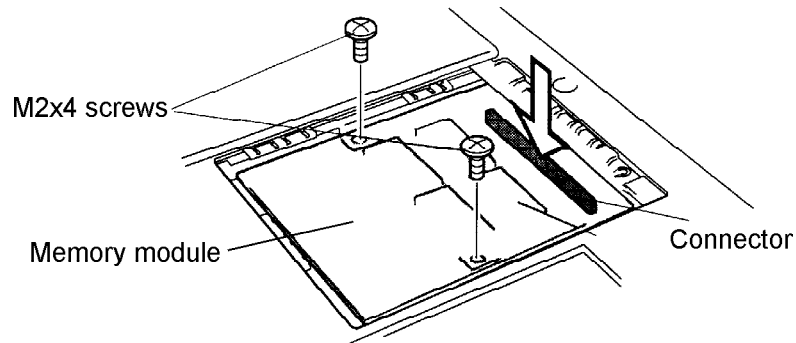

Figure 4-8 Installing the memory module

4. If the memory module has a plastic tab, fold it down first then lay the cover in place.
5. Secure it with **two silver M2x4 screws**.
6. Install the battery pack and optional PC card as described in Sections 4.3 and 4.2.

NOTE: There are two holes for the screw securing the memory module on one side. When the module is installed, use the inside hole to secure the module. Otherwise, secure the screw to the outside hole.

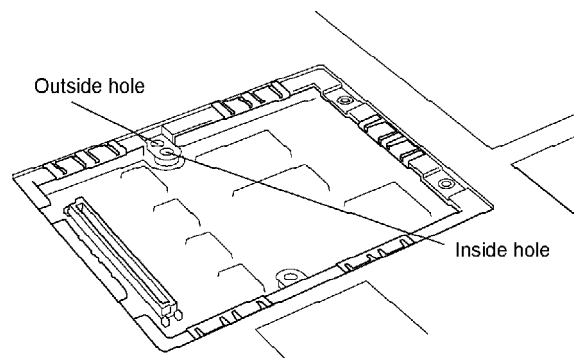

Figure 4-9 Securing the screw

4.5 Floppy Disk Drive (FDD)

Removing the FDD

To remove the FDD, follow the steps below and refer to Figures 4-10 to 4-13.

1. Turn off the power to the computer. Disconnect the AC power cord and all external cables connected to the computer.
2. Remove the battery pack, optional PC card, and optional memory module as described in Sections 4.2, 4.3, and 4.4.
3. Turn the computer upside down.
4. Press the **release lever lock** to unlock the **release lever**.
5. Pull up on the lever to release it. Then, raise it gently until the FDD pops out slightly. Don't force the lever back too far.

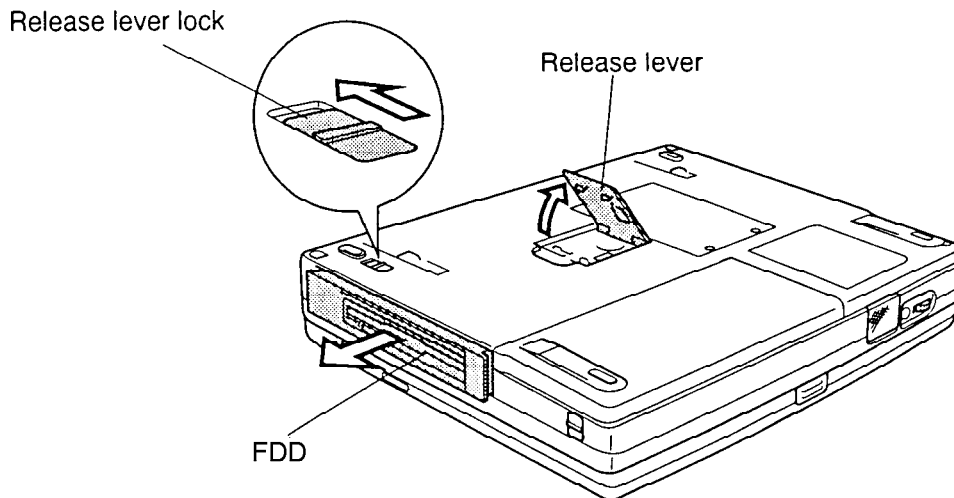

Figure 4-10 Removing the FDD module

6. Grasp the drive and pull it out.

7. Remove **six M2x6 screws** and take off the **upper plastic cover**.

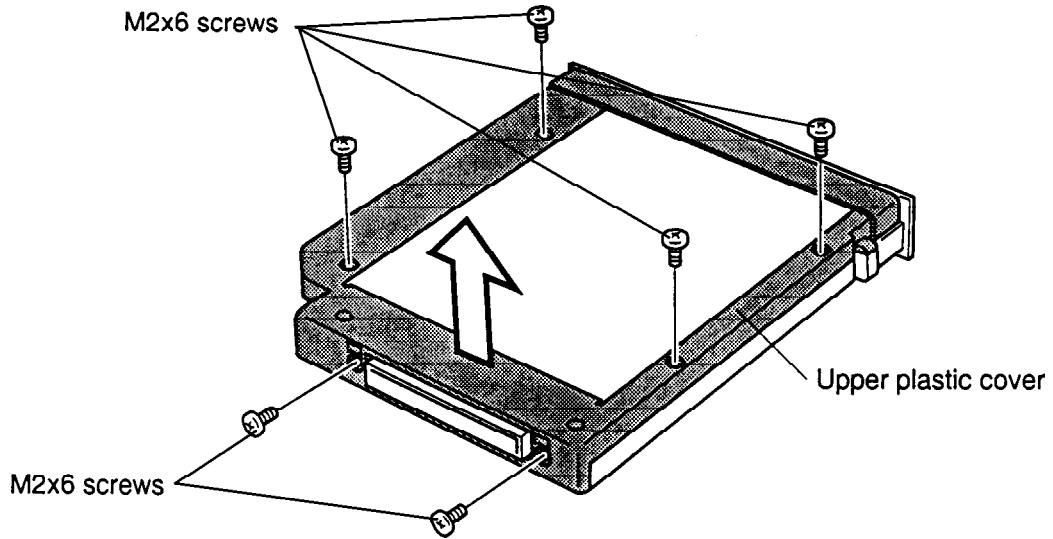

Figure 4-11 Removing the screws

8. Release **four latches**, lift off the **plate**, and remove the **lower plastic cover**.

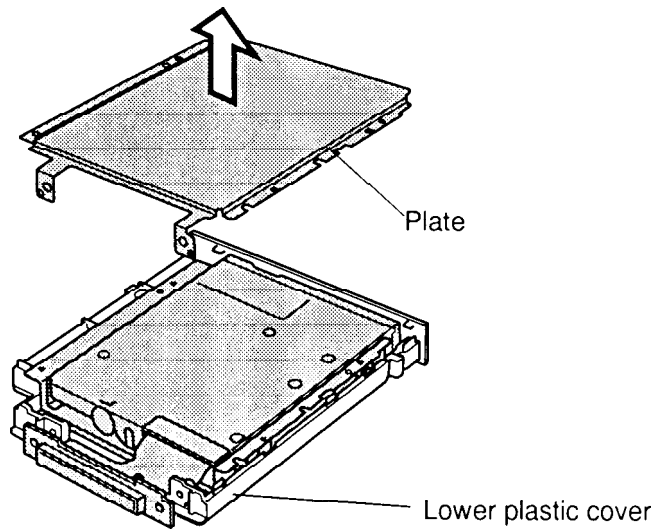

Figure 4-12 Removing the plate

9. Disconnect the **flexible cable**.
10. Remove **four M2x3 screws** and remove the FDD from the bracket.

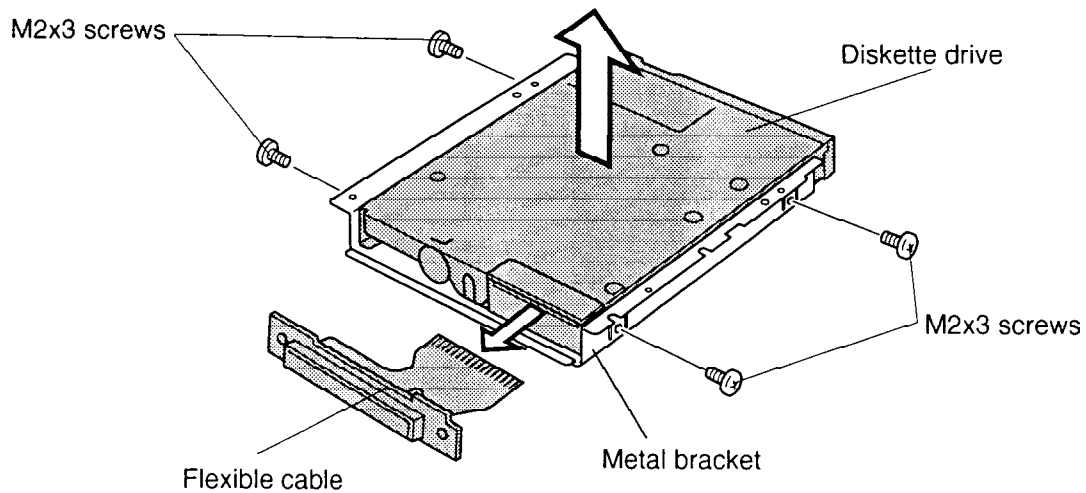

Figure 4-13 Removing the FDD

Installing the FDD

To install the FDD, follow the steps below and refer to Figures 4-13 back to 4-10.

1. Seat the **FDD** in the **metal bracket** and secure **four M2x3 screws**.
2. Connect the **flexible cable**.
3. Set the **plate** in place and seat the **FDD** in the **lower plastic cover**.
4. Set the **upper plastic cover** in place and secure **six M2x6 screws**. Press firmly to engage latches.
5. Slowly insert the **FDD module** into the computer. Be careful to insert the drive straight and press gently so the drive is flush with the computer.
6. Hold the **FDD module** flush to the computer and push the lever down until it snaps into place.
7. Lock the **release lever lock**.
8. Install the optional memory module, optional PC card, and battery pack as described in Sections 4.4, 4.3, and 4.2.

4.6 CD-ROM Drive

Removing the CD-ROM Drive

To remove the CD-ROM drive, follow the steps below and refer to Figures 4-14 and 4-15.

1. Turn off the power to the computer. Disconnect the AC power cord and all external cables connected to the computer.
2. Remove the battery pack, optional PC card, and optional memory module as described in Sections 4.2, 4.3, and 4.4.
3. Turn the computer upside down.
4. Press the **release lever lock** to unlock the **release lever**.
5. Pull up on the lever to release it. Then, raise it gently until the **CD-ROM drive module** pops out slightly. Don't force the lever back too far.

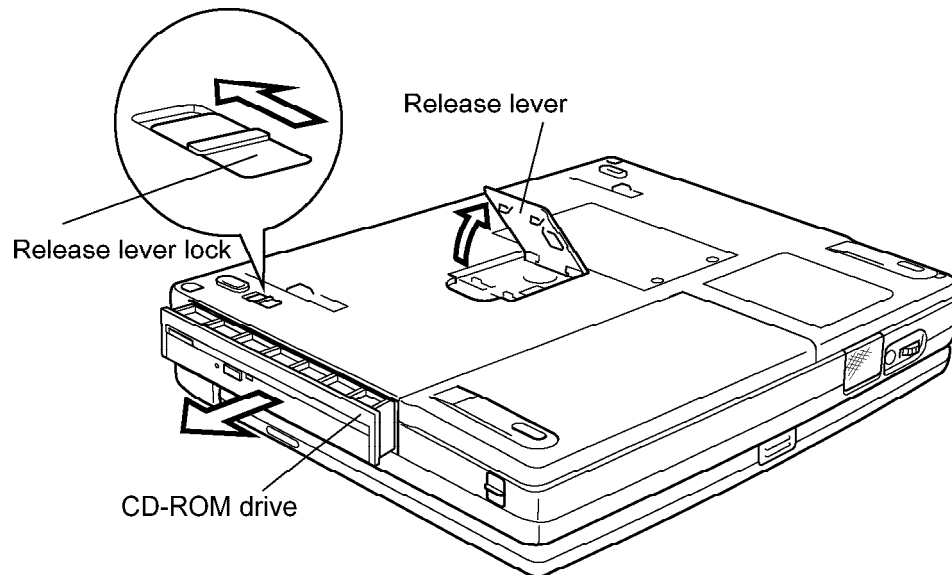

Figure 4-14 Removing the CD-ROM drive module

6. Grasp the drive and pull it out.

7. Remove **four M2x3 screws** and **three M2x6 screws** securing the frame to the CD-ROM drive.

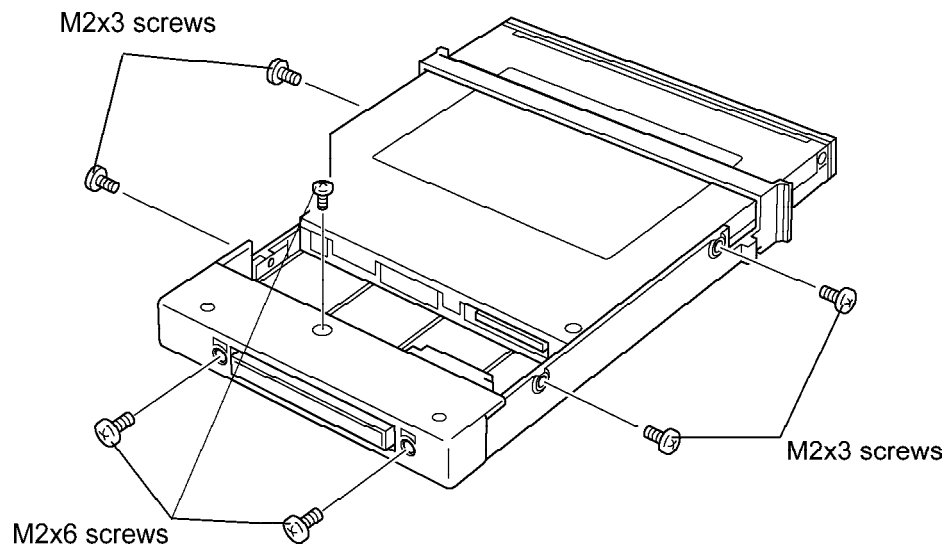

Figure 4-15 Removing the screws

8. Release **two latches** and remove the front cover.
9. Disconnect the flexible cable from the drive.
10. Hold unit with the drive door facing away and push forward with thumbs to slide the **drive** out of the case.

Installing the CD-ROM Drive

To install the CD-ROM drive, follow the steps below and refer to Figures 4-15 and 4-14.

1. Push the **CD-ROM drive** fully into the case.
2. Connect the **flexible cable** to the drive.
3. Replace the **front cover** and press firmly to engage latches.
4. Secure the frame to the drive with **four M2x3 screws** and **three M2x6 screws**.
5. Slowly insert the **CD-ROM drive module** into the computer. Be careful to insert it straight and press firmly so the drive is flush with the computer. The **release lever** will close partially.
6. Hold the **CD-ROM drive module** flush to the computer and push the lever down until it snaps into place.
7. Lock the drive **release lever lock**.
8. Install the optional memory module, optional PC card, and battery pack as described in Sections 4.2, 4.3, and 4.4.

4.7 Hard Disk Drive (HDD)

Removing the HDD

To remove the HDD drive, follow the steps below and refer to Figures 4-16 and 4-17.

1. Turn off the power to the computer. Disconnect the AC power cord and all external cables connected to the computer.
2. Remove the battery pack, optional PC card, optional memory module and FDD or CD-ROM drive as described in Sections 4.2 through 4.6.
3. Remove **two M2.5x6 screws** securing the **HDD frame brace** to the computer.
4. Pull the frame forward by its handle to disconnect the **HDD**.
5. Remove the frame and brace with the HDD.

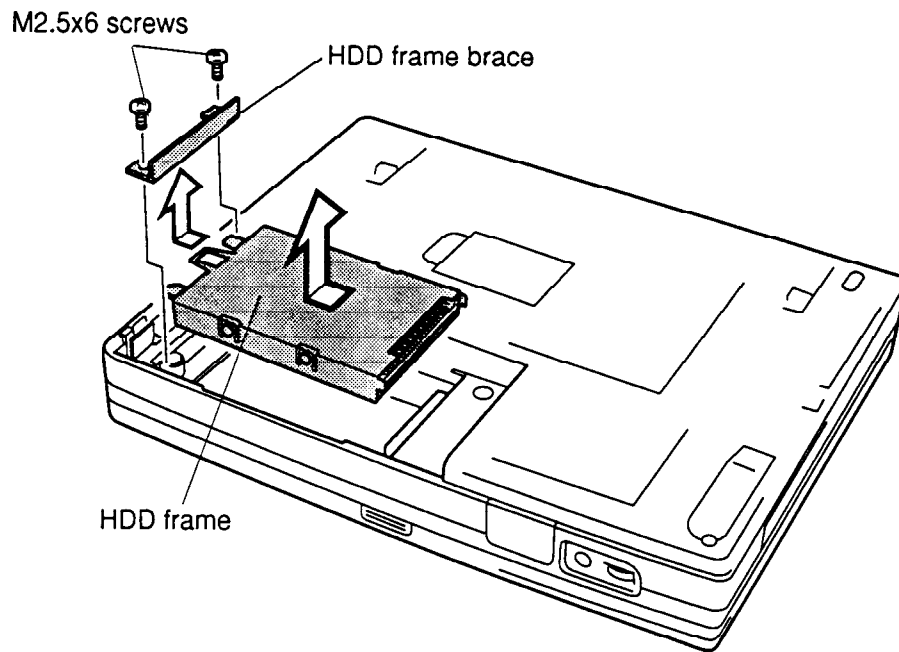

Figure 4-16 Removing the frame with the HDD

6. Remove **four flat-head M3x4 screws** securing the frame to the HDD and separate the HDD from the frame.

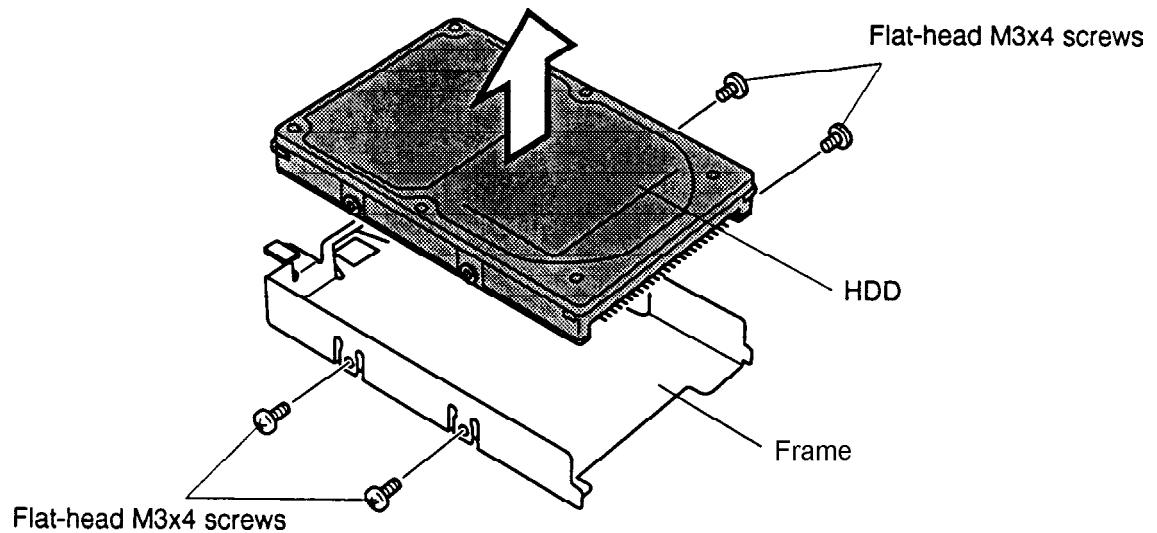

Figure 4-17 Removing the HDD from the frame

Installing the HDD Drive

To install the HDD drive, follow the steps below and refer to Figures 4-17 and 4-16.

1. Secure the **frame** to the **HDD** with four **flat-head M3x4 screws**.
2. Attach the **HDD frame brace** to the **HDD frame**.
3. Seat the HDD in the computer and press to secure the connection.
4. Secure the HDD frame to the computer with **two M2.5x6 screws**.
5. Install the FDD or CD-ROM drive, optional memory module, optional PC card, and battery pack as described in Sections 4.6 back through 4.2.

4.8 Keyboard

Removing the Keyboard

To remove the keyboard, follow the steps below and refer to Figures 4-18 to 4-20.

1. Turn off the power to the computer. Disconnect the AC power cord and all external cables connected to the computer.
2. Remove the battery pack, optional PC card, optional memory module, FDD or CD-ROM drive and HDD as described in Sections 4.2 through 4.7.
3. Release **14 latches** on the **base cover** and remove it. Begin along the front side.

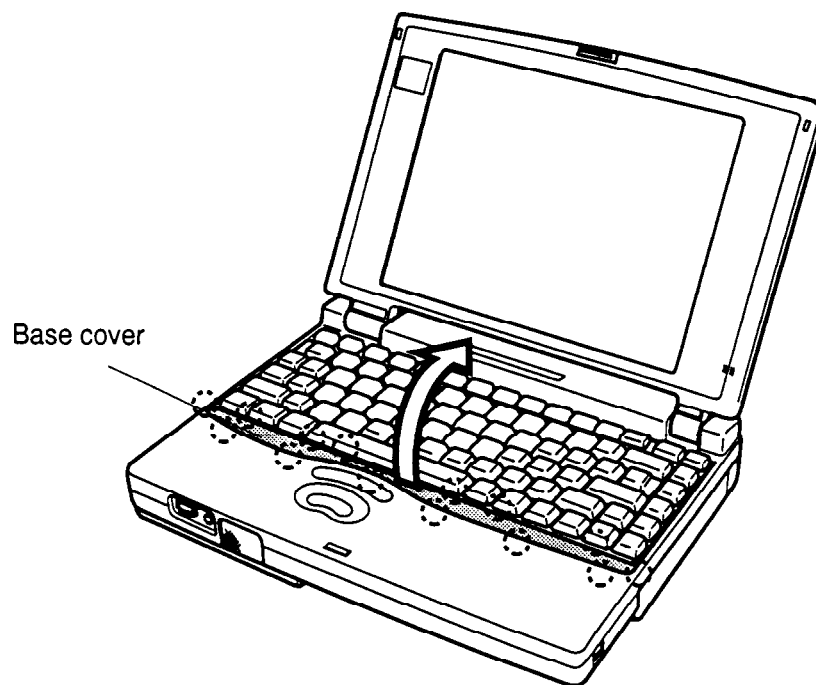

Figure 4-18 Removing the keyboard base

4. Lift out the keyboard and set it on the wrist rest.
5. Remove tape from the keyboard connector cover.
6. Remove **two M2.5x6 screws** securing the **keyboard connector cover** and remove it.

NOTE: Some units may have a keyboard connector cover that slides over the keyboard cable. If so, do the following:

1. Remove one M2.5x6 screw and slide the cover along the keyboard cable enough to access the keyboard connector.
2. Remove four M2.5x6 screws holding the metal cover and lift it out.
3. Continue with Step 8.

7. Remove **three M2.5x6 screws** securing the **metal cover** and lift out the metal cover.

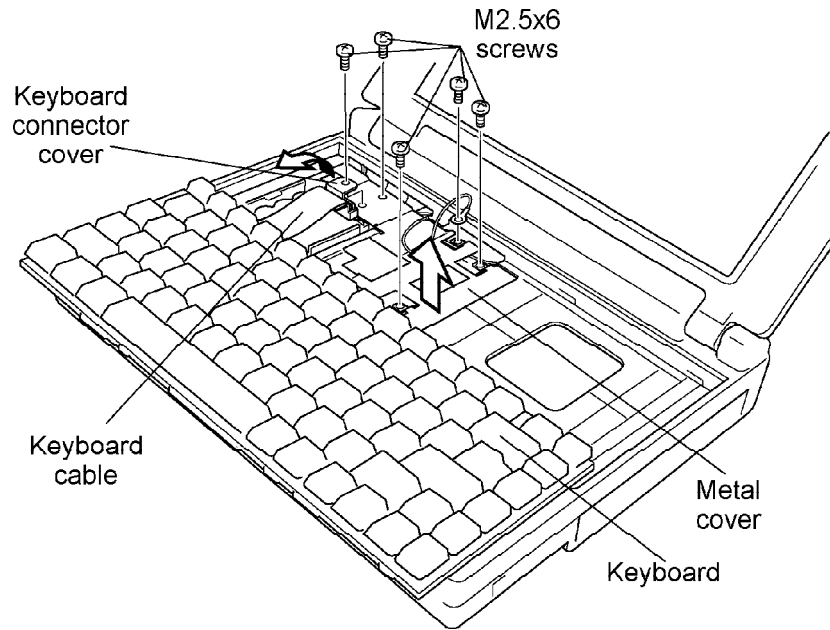

Figure 4-19 Removing the metal cover

8. Disconnect the **keyboard cable** from **PJ13** on the system board and lift out the keyboard.

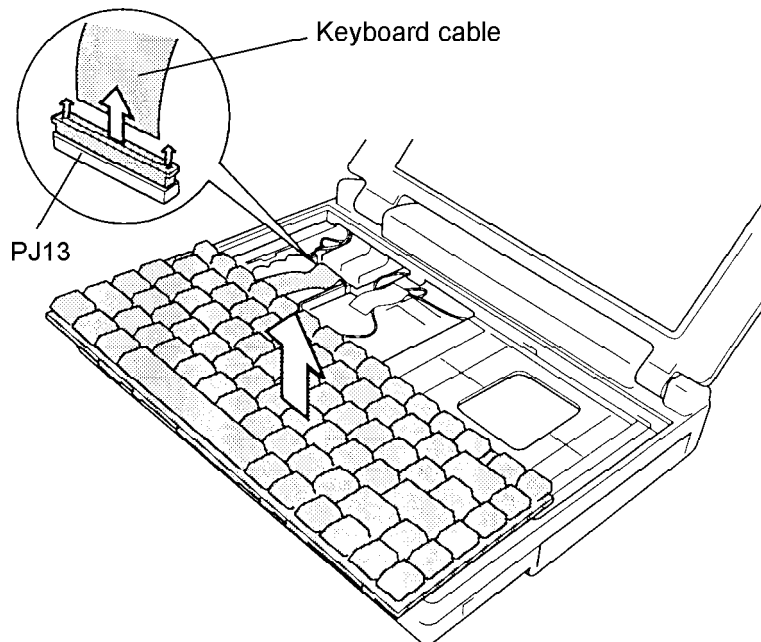

Figure 4-20 Removing the keyboard

NOTE: If the unit under repair has a keyboard connector cover that slides along the keyboard cable, then pull out the keyboard connector cover from the keyboard cable at this point.

Installing the Keyboard

To install the keyboard, follow the steps below and refer to Figures 4-21 back to 4-18.

1. Connect the keyboard cable to **PJ13** on the system board. Make sure the cable connection is secure.
2. Fit the two tabs of the metal cover into the top cover and backup battery base (see Figure 4-21), then seat the **metal cover** and secure it with **three M2.5x6 screws**. Make sure the plastic tab on the LED connector is under the metal cover.

NOTE: If the unit under repair has a keyboard connector cover that slides along the keyboard cable, then first thread the **keyboard cable** through the hole in the keyboard connector cover. The metal cover for this kind of connector has **four M2.5x6 screws**.

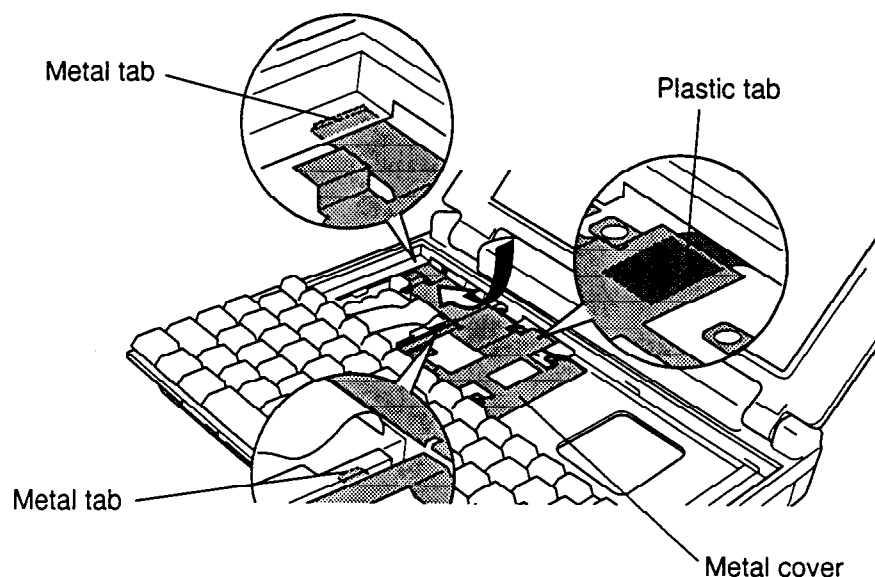

Figure 4-21 Seating the metal cover

3. Fit the **keyboard connector cover** on the metal cover and secure it with **two M2.5x6 screws** (or **one M2.5x6 screw w/washer** if the unit has a sliding connector cover).
4. Replace the tape.
5. Fit tabs on the back of the keyboard into corresponding holes on the computer and lay the keyboard in place.
6. Secure **six latches** on the back of the **keyboard base**, **two latches** at the ends, and **six latches** along the front.
7. Install the HDD, FDD or CD-ROM drive, optional memory module, optional PC card, and battery pack as described in Sections 4.7 back through 4.2.

4.9 Sub-Battery and VGA Board

Removing the Sub-Battery and VGA Board

To remove the sub-battery and VGA board, follow the steps below and refer to Figures 4-22 to 4-25.

1. Turn off the power to the computer. Disconnect the AC power cord and all external cables connected to the computer.
2. Remove the battery pack, optional PC card, optional memory module, FDD or CD-ROM drive, HDD, and keyboard as described in Sections 4.2 through 4.8.
3. Disconnect the **sub-battery cable** from **PJ503** and remove the battery.

WARNING: If you replace the sub-battery, be sure to use only batteries recommended by Toshiba. Installation of the wrong battery can cause the battery to explode or otherwise cause damage.

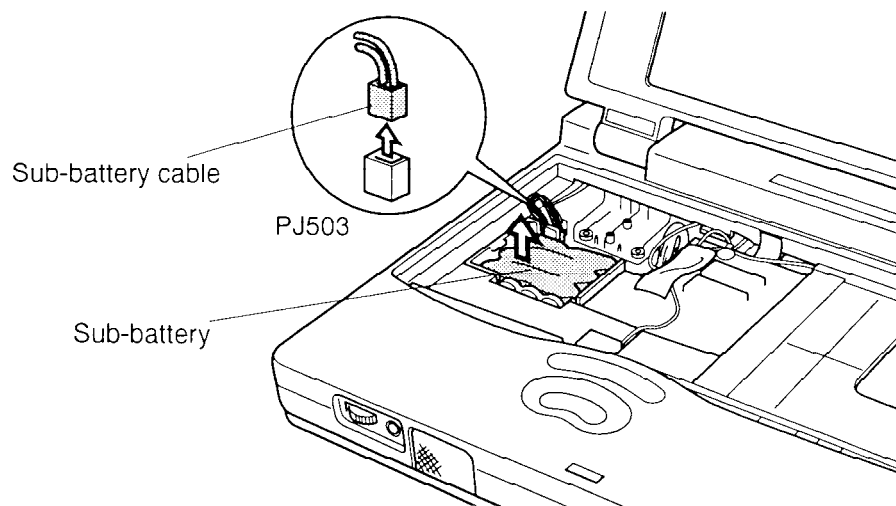

Figure 4-22 Removing the sub-battery

4. The battery is held in place by two-sided tape. Press down firmly on the battery holder and gently pry up to release the battery.

5. Remove two tapes and disconnect the **microphone cable** from **PJ3** on the sound board.

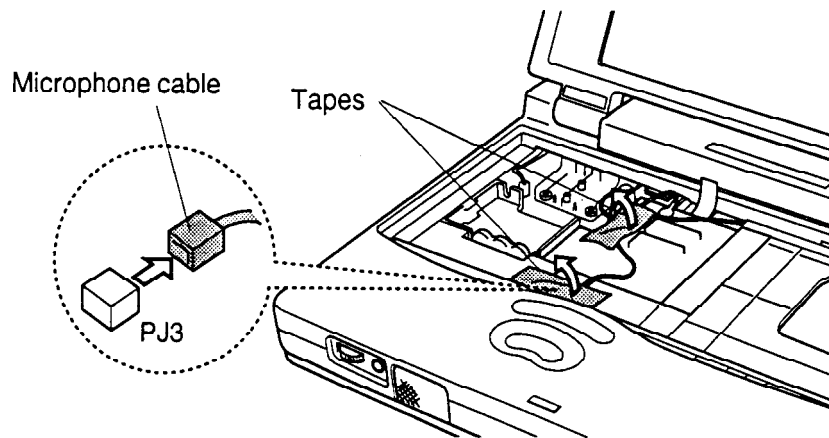

Figure 4-23 Disconnecting the microphone cable

6. Disconnect the **VGA board** from system board connector **PJ16**.

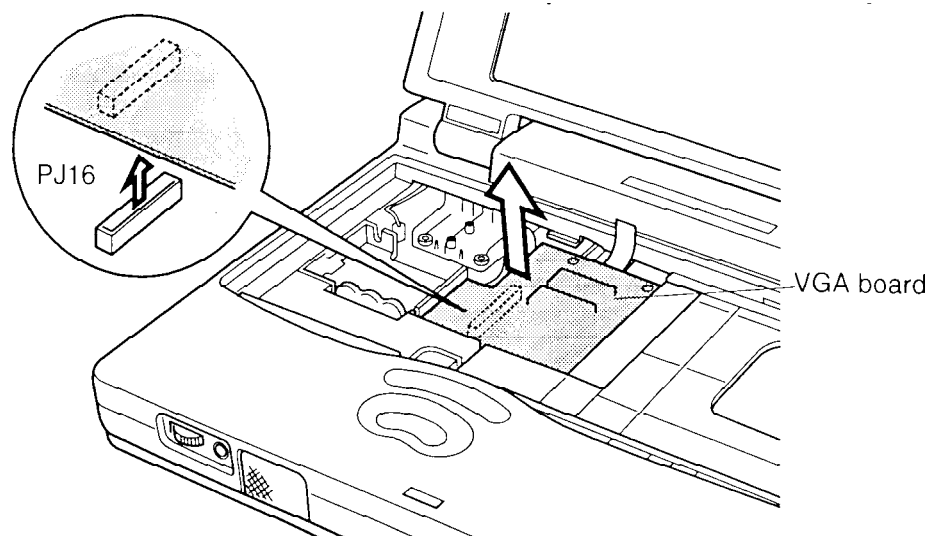

Figure 4-24 Disconnecting the VGA board

7. Rotate the VGA board out and disconnect the **VGA cables** from **PJ302** and **PJ303 (TFT model only)** on the VGA board.

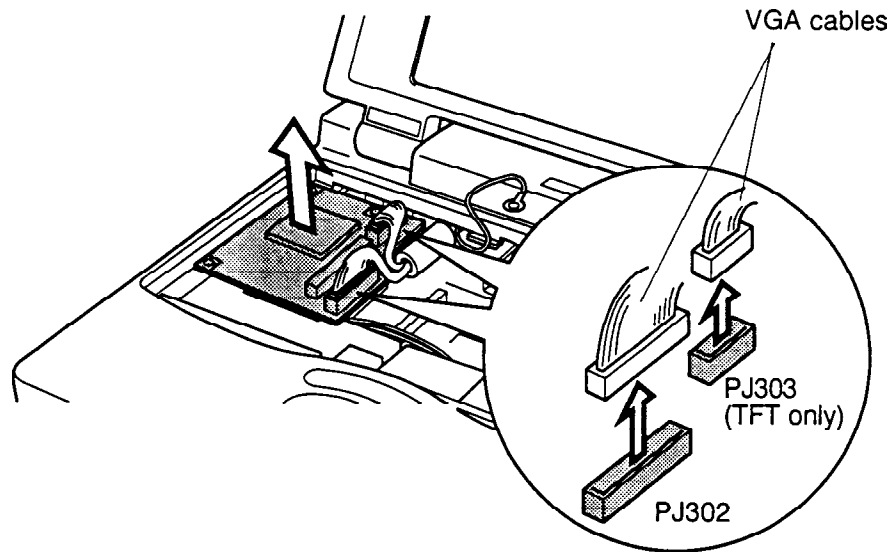

Figure 4-25 Disconnecting the cables from the VGA board

Installing the Sub-Battery and VGA Board

To install the sub-battery and VGA board, follow the steps below and refer to Figures 4-26 back to 4-22.

1. Connect the **VGA cable** to **PJ302** and **PJ303 (TFT model only)** on the **VGA board**. Make sure the **ferrite core** is seated properly.

NOTE: Make sure connectors **PJ301** on the VGA board and **PJ16** on the system board are not dirty. If they are dirty, clean them. If a connector is broken, replace the VGA board or system board with a new one.

2. Be sure the microphone cable is on top of the VGA board and rotate the board into place. When it is seated flat, press evenly to connect the **VGA board connector** to **PJ16** on the system board.
3. Connect the **microphone cable** to **PJ3** on the sound board. Route the cable in a groove on the top cover and secure it with two tapes.
4. Seat the **sub-battery** and connect the cable to **PJ503** on the system board.

CAUTION: Be sure to connect the sub-battery connector to the white socket, not the orange one. The orange socket, **PJ10**, is for the panel close sensor cable. If these connectors are switched, the system will be damaged.

5. Use a multimeter to measure the **TP2 (+)** and ground voltage according to the following value.

TP2 6.0 V to 8.0 V

If the voltage is too low, replace the sub-battery with a new one.

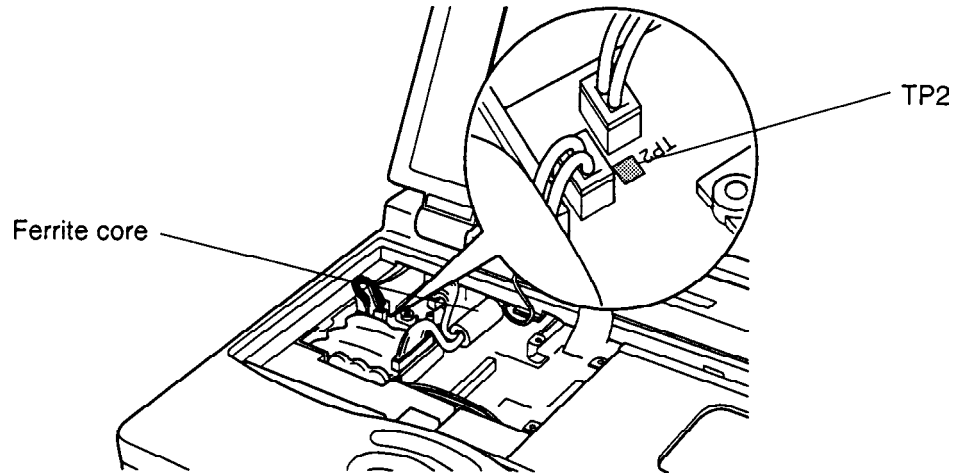

Figure 4-26 Measuring the voltage at TP2

6. Install the keyboard, HDD, FDD or CD-ROM drive, optional memory module, optional PC card, and battery pack as described in Sections 4.7 back through 4.2.

4.10 RTC Battery and Top Cover with Display Assembly

Removing the RTC Battery and Top Cover with Display Assembly

To remove the RTC battery and top cover with display assembly, follow the steps below and refer to Figures 4-27 to 4-29.

1. Turn off the power to the computer. Disconnect the AC power cord and all external cables connected to the computer.
2. Remove the battery pack, optional PC card, optional memory module, FDD or CD-ROM drive, HDD, keyboard, sub-battery, and VGA board as described in Sections 4.2 through 4.9.
3. Turn the computer upside down and remove **three M2.5x8 silver screws** and **four M2.5x6 screws** securing the top cover and display assembly.

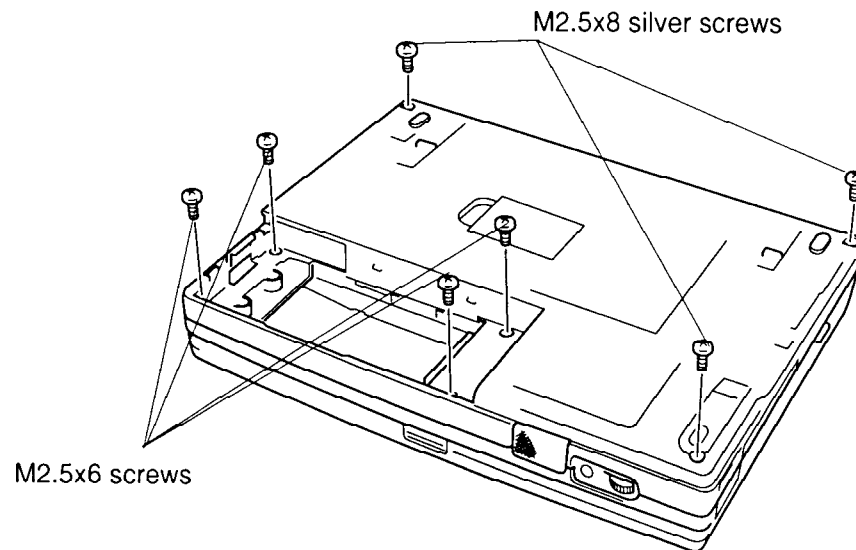

Figure 4-27 Removing the top cover screws

4. Turn the computer over and lift back the **top cover** and **display assembly** so you can disconnect the cables.

5. Disconnect the **Real Time Clock battery cable** from **PJ3** on the system board and remove the battery.

WARNING: If you replace the RTC battery, be sure to use only batteries recommended by Toshiba. Installation of the wrong battery can cause the battery to explode or otherwise cause damage.

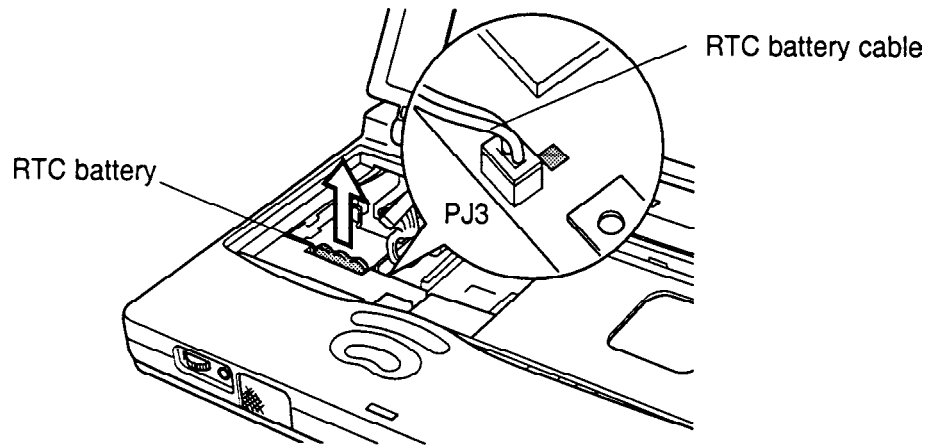

Figure 4-28 Removing the RTC battery

6. Disconnect the **panel close sensor cable** from **PJ10**.
7. Pull the LED cable tab, then remove the **LED cable** from **PJ14** on the system board.
8. Remove **one M2.5x8 screw** from the sub-battery base.
9. Remove the **tape** securing the **ground cable** and **one M2.5x6 screw** from the system board with **ground cable**.
10. Release **two latches** at the back of the computer and **four latches** at the front and lift up the top cover with display assembly. Be careful to clear the sound jack.

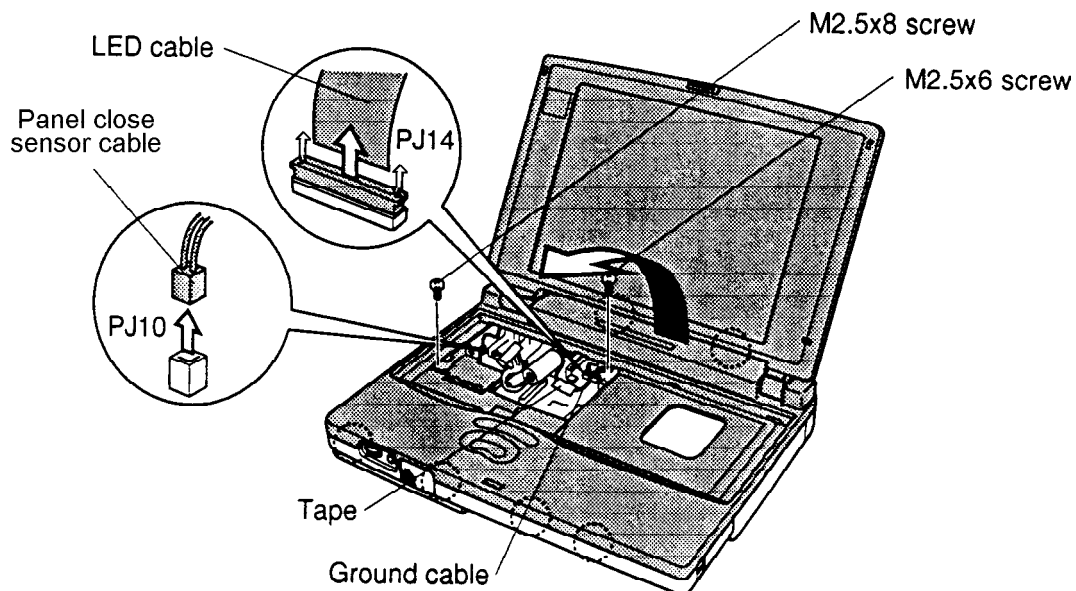

Figure 4-29 Removing the top cover with display assembly

Installing the RTC Battery and Top Cover with Display Assembly

To install the RTC battery and top cover with display assembly, follow the steps below and refer to Figures 4-30 back to 4-27.

1. Seat the **top cover** and **display assembly** then secure two latches at the back of the computer and four latches at the front. Be careful to seat the left front corner over the sound jacks.
2. Connect the **LED cable** to **PJ14**. Make sure the cable connection is secured with the pressure plate.
3. Connect the **panel close sensor cable** to **PJ10** on the system board.

CAUTION: Be sure to connect the panel close sensor cable to the orange socket, not the white one. The white socket, PJ503, is for the sub-battery cable. If these connectors are switched, the system will be damaged.

4. Secure the **ground cable** with **one M2.5x6 screw** on the system board.
5. Secure the sub-battery base with **one M2.5x8 screw**.
6. Connect the **Real Time Clock battery** to **PJ3** on the system board. Using the multimeter, measure the voltage on the test point of **PJ3**.

+2V to 4V

If the voltage is too low, replace the RTC battery with a new one.

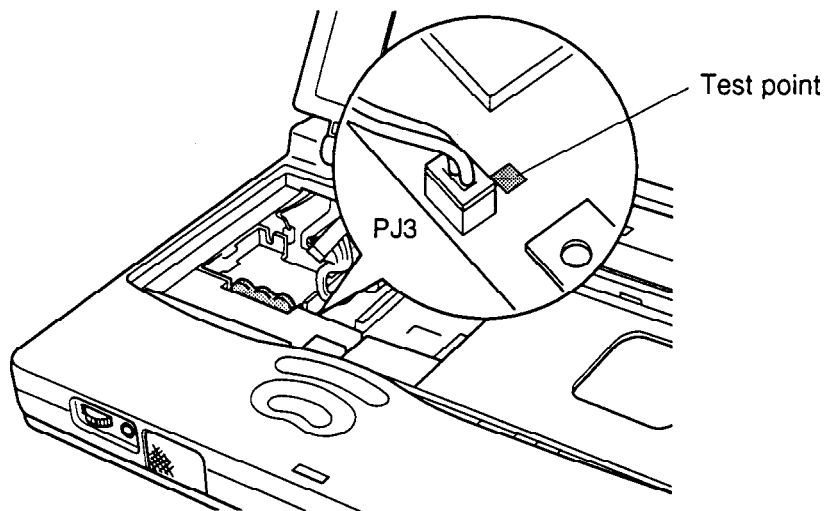

Figure 4-30 Measuring the voltage at PJ3

7. Turn the computer upside down and secure **three M2.5x8 silver screws** and **four M2.5x6 screws**.
8. Install the sub-battery, VGA board, keyboard, HDD, FDD or CD-ROM drive, optional memory module, optional PC card, and battery pack as described in Sections 4.9 back through 4.2.

4.11 Sound Board and Membrane Switch

Removing the Sound Board and Membrane Switch

To remove the sound board and membrane switch, follow the steps below and refer to Figures 4-31 to 4-33.

1. Turn off the power to the computer. Disconnect the AC power cord and all external cables connected to the computer.
2. Remove the battery pack, optional PC card, optional memory module, FDD or CD-ROM drive, HDD, keyboard, sub-battery, VGA board, RTC battery and top cover with display assembly as described in Sections 4.2 through 4.10.
3. Remove **five M2.5x6 screws** (one w/washer) and **one M2.5x4 screw** securing the **sound board cover, HDD metal cover, and Selectable Bay ground plate**.
4. Remove the sound board cover, HDD metal cover, and Selectable Bay ground plate.

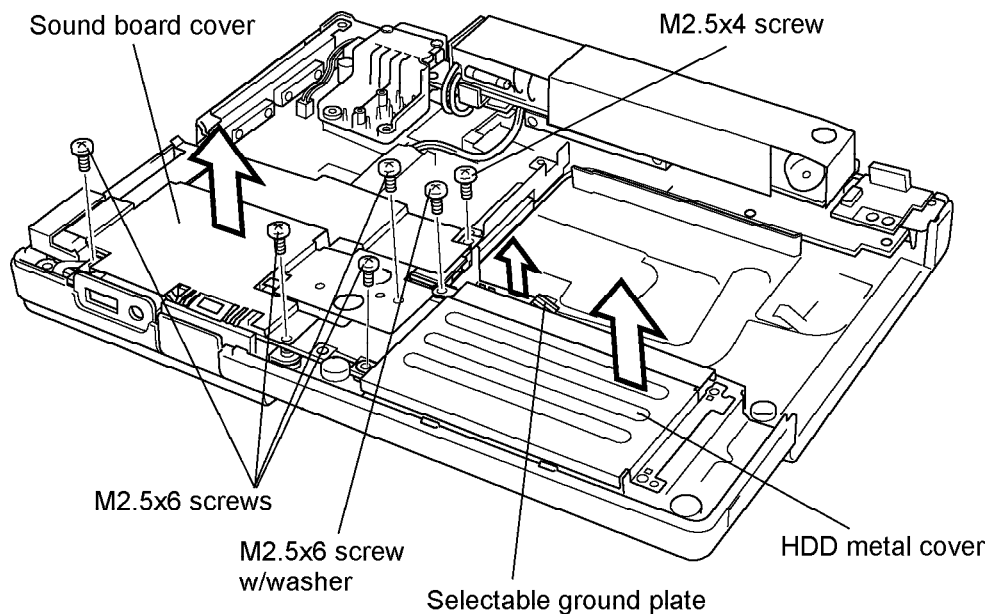

Figure 4-31 Removing the sound board cover

5. Remove the tape from the **speaker cable** and disconnect the **speaker cable** from **PJ6** on the sound board.
6. Disconnect the **sound board power cable** from **PJ9** on the sound board.
7. Disconnect the **CD-ROM sound cable** from **PJ11** on the sound board.
8. Press up on the **sound board flexible cable** evenly to disconnect it from **PJ7** on the system board. Lift out the **sound board**.
9. Disconnect the **sound board power cable** from **PJ18** on the system board (located under left side of power supply cover - this cover is not removed until section 4.12.)

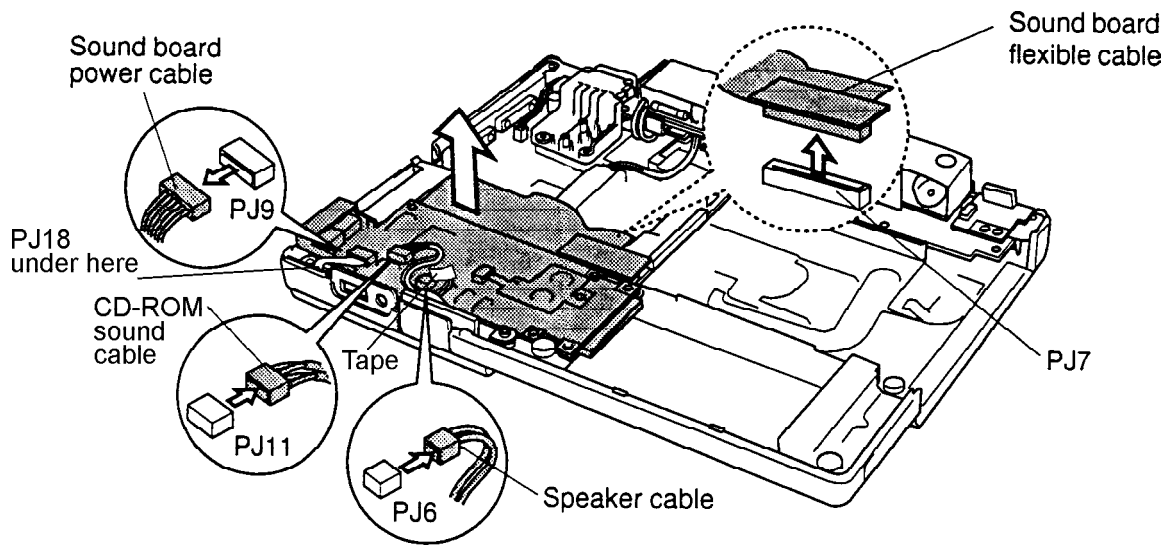

Figure 4-32 Removing the sound board

10. Unlatch the **audio jack cover** and remove it.
11. Lift off the tape securing the **membrane switch**, disconnect the **membrane switch cable** from **PJ10** and lift out the switch.

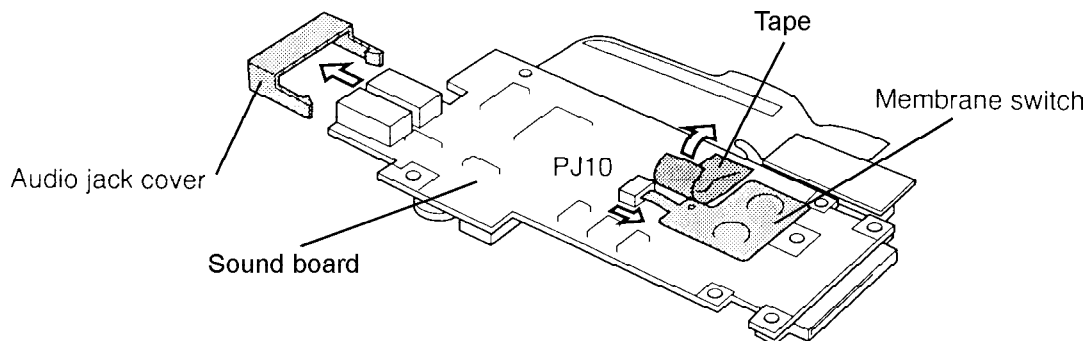

Figure 4-33 Removing the membrane switch

Installing the Sound Board and Membrane Switch

To install the sound board and membrane switch, follow the steps below and refer to Figures 4-33 back to 4-31.

1. Align holes in the **membrane switch** with corresponding holes on the sound board. Connect the cable to **PJ10**, and secure it with **tape**.
2. Attach the **audio jack cover**.
3. Connect the **sound power cable** to **PJ18** on the system board (under the power supply cover).
4. Seat the **sound board**. Make sure the **volume control** and **headphone jack** fit through corresponding holes in the computer. Also, make sure pins fit through corresponding holes in the membrane switch.

***NOTE:** Route three cables: sound board power cable, CD-ROM sound cable and speaker cable on top of the sound board.*

5. Align the **flexible cable** connector with **PJ7** on the **system board** and press evenly to make the connection.
6. Replace the **HDD metal cover**.
7. Connect three cables: **sound board power cable** to **PJ9**, **CD-ROM sound cable** to **PJ11**, and **speaker cable** to **PJ6**.
8. Secure the cables with **tape**.
9. Seat the **sound board cover**, **HDD metal cover**, and **Selectable Bay ground plate**.
10. Secure the sound board, sound board cover, HDD metal cover, and Selectable Bay ground plate with **five M2.5x6 screws** (one w/washer) and **one M2.5x4 screw**.

***NOTE:** Be sure to secure the M2.5x4 screw to the correct hole.*

11. Install the top cover with display assembly, RTC battery, sub-battery, VGA board, keyboard, HDD, FDD or CD-ROM drive, optional memory module, optional PC card, and battery pack as described in Sections 4.10 back through 4.2.

4.12 Speaker

Removing the Speaker

To remove the speaker, follow the steps below and refer to Figures 4-34 and 4-35.

1. Turn off the power to the computer. Disconnect the AC power cord and all external cables connected to the computer.
2. Remove the battery pack, optional PC card, optional memory module, FDD or CD-ROM drive, HDD, keyboard, sub-battery, VGA board, RTC battery, top cover with display assembly and sound board as described in Sections 4.2 through 4.11.
3. Remove the **tape** securing the **CD-ROM sound cable** and disconnect it from **PJ19** on the system board. Note the location of the tape.
4. Remove **one M2.5x6 screw** securing the **power supply cover** and remove the cover.
5. Remove **one M2.5x6 screw** securing the speaker assembly and lift out the speaker.

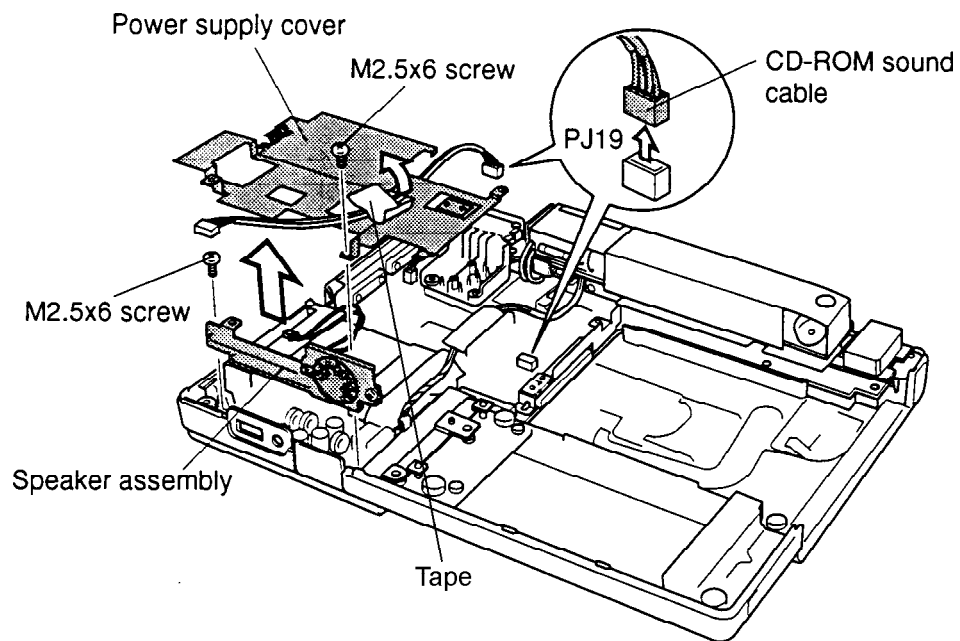

Figure 4-34 Removing the speaker assembly

6. Remove **one M2.5x4 screw** securing the **speaker** and its **brace**.

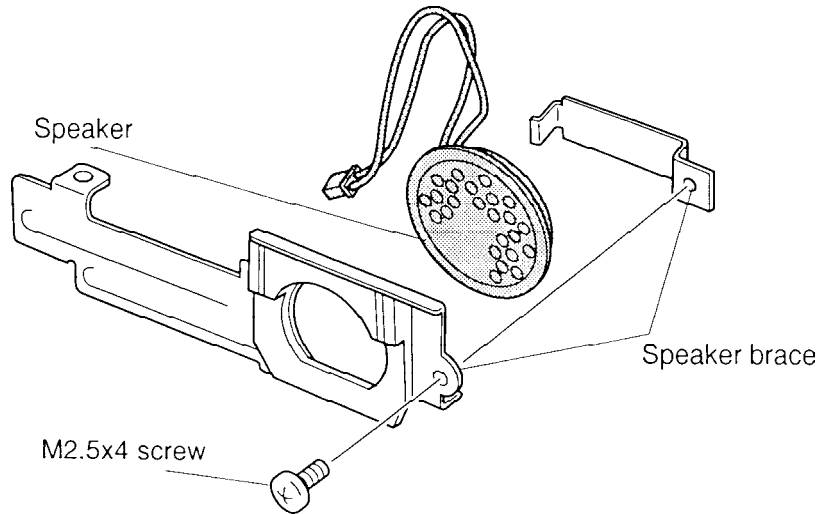

Figure 4-35 Removing the speaker

Installing the Speaker

To install the speaker, follow the steps below and refer to Figures 4-35 and 4-34.

1. Seat the **speaker** in the **speaker brace** and secure it with **one M2.5x4 screw**.
2. Seat the **speaker assembly** and secure it to the computer with **one M2.5x6 screw**.
3. Seat the **power supply cover**. Make sure it fits under the speaker assembly and that **one pin** fits through the corresponding hole in the cover.
4. Secure the **power supply cover** with **one M2.5x6 screw**.
5. Connect the **CD-ROM sound cable** to **PJ19** on the system board. Secure it with **tape** at its original position.
6. Install the sound board, top cover with display assembly, RTC battery, VGA board, sub-battery, keyboard, HDD, FDD or CD-ROM drive, optional memory module, optional PC card, and battery pack as described in Sections 4.11 back through 4.2.

4.13 AC PS Unit

Removing the AC PS Unit

To remove the AC PS unit, follow the steps below and refer to Figures 4-36 and 4-37.

1. Turn off the power to the computer. Disconnect the AC power cord and all external cables connected to the computer.
2. Remove the battery pack, optional PC card, optional memory module, FDD or CD-ROM drive, HDD, keyboard, sub-battery, VGA board, RTC battery, top cover with display assembly, sound card and speaker as described in Sections 4.2 through 4.12.
3. Remove **one M2.5x6 screw** securing the **battery terminal cover** and lift off the cover.
4. Remove the **tape** securing the **AC PS unit cable** and disconnect it from **PJ502**. Note how the cable is threaded.
5. Remove the **tape** and **one M2.5x10 screw** securing the AC PS unit.
6. Turn the **AC PS unit** out of its seating and lay it on its side.

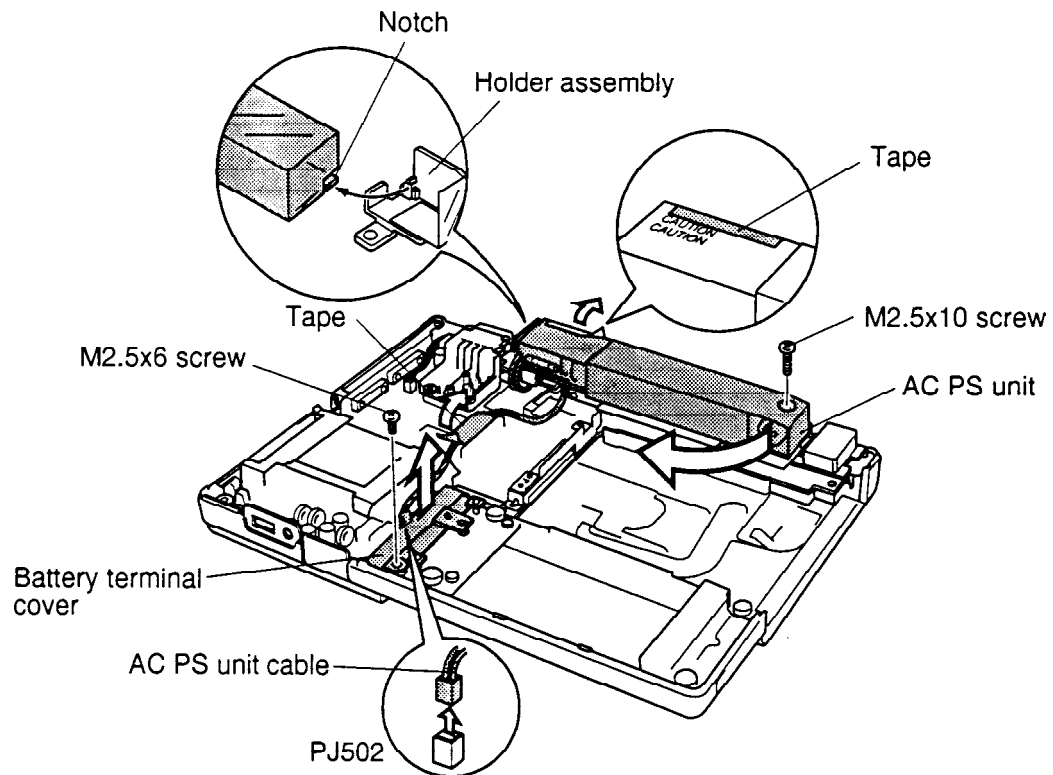

Figure 4-36 Removing the AC PS unit

7. Remove **two M2.5x6 screws** securing the **holder assembly** and **plastic cover**, then lift out the assembly.
8. Lift the **power cord socket** straight up until it clears its slots and remove the AC PS unit.

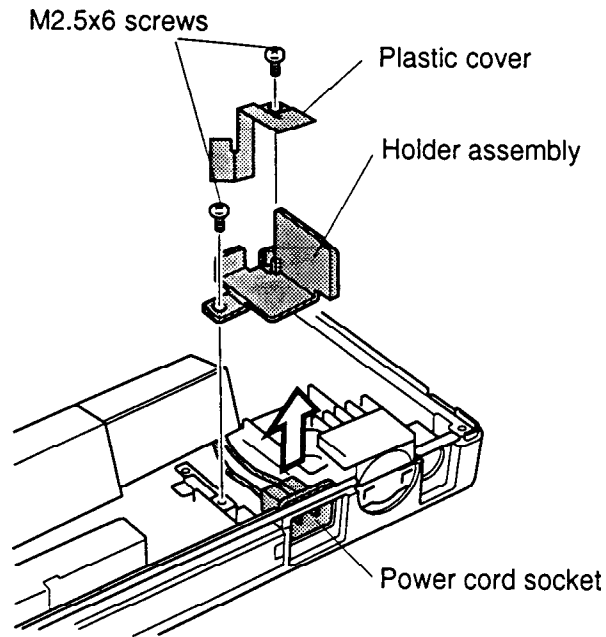

Figure 4-37 Removing the holder assembly and power cord socket

Installing the AC PS Unit

To install the AC PS unit, follow the steps below and refer to Figures 4-37 and 4-36.

1. Seat the **power cord socket** with the side with markings facing up. Press gently to secure its position.
2. Seat the **holder assembly** and **plastic cover**, then secure them with **two M2.5x6 screws**.
3. Seat the **AC PS unit**. Be sure to fit the AC PS unit's plastic cover into the notch on the holder assembly.
4. Secure the **tape** to the **plastic plate** and the **AC PS unit**. Make sure the tape is placed just above the word "CAUTION."
5. Secure the **AC PS unit** with **one M2.5x10 screw**.
6. Connect the **AC PS unit cable** to **PJ502** and secure the cable on the left side of **PJ16** with **tape**.
7. Lay the **battery terminal cover** in place (two pins should stick through) and secure it with **one M2.5x6 screw**.
8. Install the speaker, sound board, top cover with display assembly, RTC battery, sub-battery, VGA board, keyboard, HDD, FDD or CD-ROM drive, optional memory module, optional PC card, and battery pack as described in Sections 4.12 back through 4.2.

4.14 Infrared Board

Removing the Infrared Board

To remove the infrared board, follow the steps below and refer to Figure 4-38.

1. Turn off the power to the computer. Disconnect the AC power cord and all external cables connected to the computer.
2. Remove the battery pack, optional PC card, optional memory module, FDD or CD-ROM drive, HDD, keyboard, sub-battery, VGA board, RTC battery, top cover with display assembly, sound board, speaker and AC PS unit as described in Sections 4.2 through 4.13.
3. Remove one **M2.5x4 screw** securing the **infrared board**.
4. Disconnect the **infrared board cable** from **PJ101** on the **infrared board**.
5. Slide the infrared board clear of the notch on the computer and lift out the board.
6. Remove the tape securing the infrared board cable (inner harness) and disconnect it from **PJ17** on the **system board**.

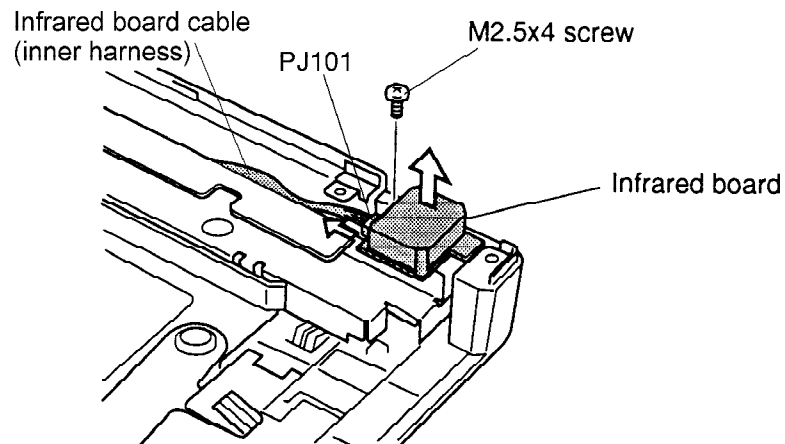

Figure 4-38 Removing the infrared board

Installing the Infrared Board

To install the infrared board, follow the steps below and refer to Figure 4-38.

1. Replace the tape and connect the infrared board cable (inner harness) to **PJ17** on the **system board**.
2. Connect the **infrared board cable** to **PJ101**.
3. Slide the **infrared board** into its notch on the computer to seat it.
4. Secure the board with **one M2.5x4 screw**.
5. Install the AC PS unit, speaker, sound board, top cover with display assembly, RTC battery, sub-battery, VGA board, keyboard, HDD, FDD or CD-ROM drive, optional memory module, optional PC card, and battery pack as described in Sections 4.13 back through 4.2.

4.15 System Board and Fan

Removing the System Board and Fan

To remove the system board and fan, follow the steps below and refer to Figures 4-39 and 4-40.

1. Turn off the power to the computer. Disconnect the AC power cord and all external cables connected to the computer.
2. Remove the battery pack, optional PC card, optional memory module, FDD or CD-ROM drive, HDD, keyboard, sub-battery, VGA board, RTC battery, top cover with display assembly, sound board, speaker, AC PS unit and infrared board as described in Sections 4.2 through 4.14.
3. Remove **six M2.5x6**, **one M2x8**, and **two M2.5x4 screws** securing the **system board**, **Selectable Bay connector cover**, **VGA support**, **ground plate**, and **back guide assembly support**.
4. Lift off the **Selectable Bay connector cover**, **VGA support**, **back guide assembly support**, and **ground plate**, then lift up the front side of the **system board** and remove the board.

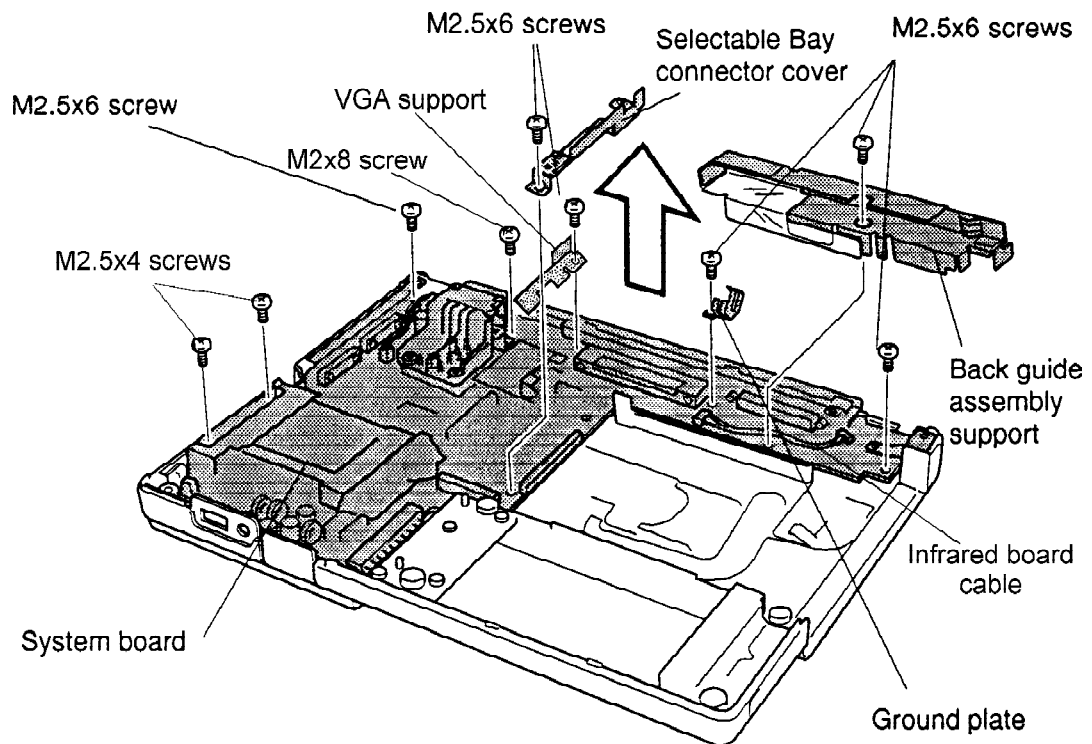

Figure 4-39 Removing the system board

5. Remove the **reset switch spring** from the system board.

NOTE: The shutter assembly for the optional PC card may fall off as you remove the system board, be sure to note its location.

6. Disconnect the **fan cable** from **PJ11** and remove **two M2.5x6 screws**. The **ground plate** for the CPU heat sensor will be removed with the left screw .

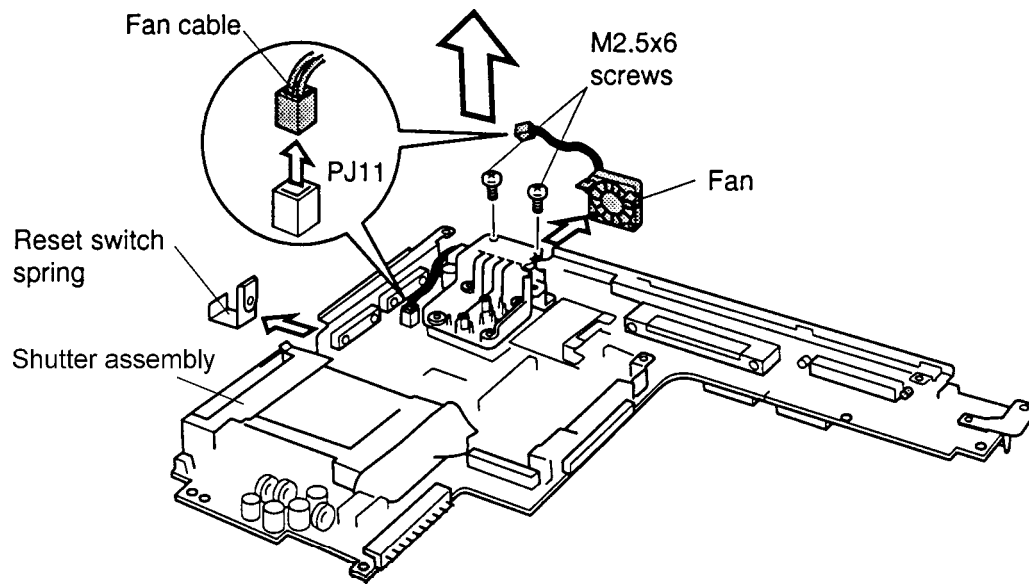

Figure 4-40 Removing the fan

Installing the System Board and Fan

To install the system board, follow the steps below and refer to Figures 4-40 and 4-39.

1. Seat the **fan** in the **system board** and secure it with **two M2.5x6 screws**. Be sure the screw on the left secures the ground plate.
2. Connect the **fan cable** to **PJ11**.
3. Seat the **reset switch spring** on the system board.
4. To reinstall the shutter assembly for the PC card, pull the eject button out as far as it will go, then insert the assembly and reset the eject button.
5. Set the back edge of the **system board** into the computer's I/O port side and lower the board into place.
6. Secure **one M2.5x6 screw** in the upper right corner of **system board** (under back guide assembly support).
7. Seat the **VGA support, back guide assembly support, Selectable Bay connector cover, and ground plate**.
8. Secure the system board with **five M2.5x6, one M2x8, and two M2.5x4 screws**.
9. Install the infrared board, AC PS unit, speaker, sound board, top cover with display assembly, RTC battery, sub-battery, VGA board, keyboard, HDD, FDD or CD-ROM drive, optional memory module, optional PC card, and battery pack as described in Sections 4.14 back through 4.2.

4.16 Display Mask

Removing the Display Mask

To remove the display mask, follow the steps below and refer to Figures 4-41 and 4-42.

1. Turn off the power to the computer. Disconnect the AC power cord and all external cables connected to the computer.
2. Remove the battery pack, optional PC card and optional memory module as described in Sections 4.2, 4.3, and 4.4.

NOTE: *It is not necessary to remove the top cover with display assembly.*

3. Remove **two seals** from the display hinges and **two rubber cushions** from the top corners to expose screws securing the **display mask**.

NOTE: *Support the back of the display with your hand when you remove the screws.*

4. Remove **four M2.5x6 screws** that were covered by the seals and cushions.

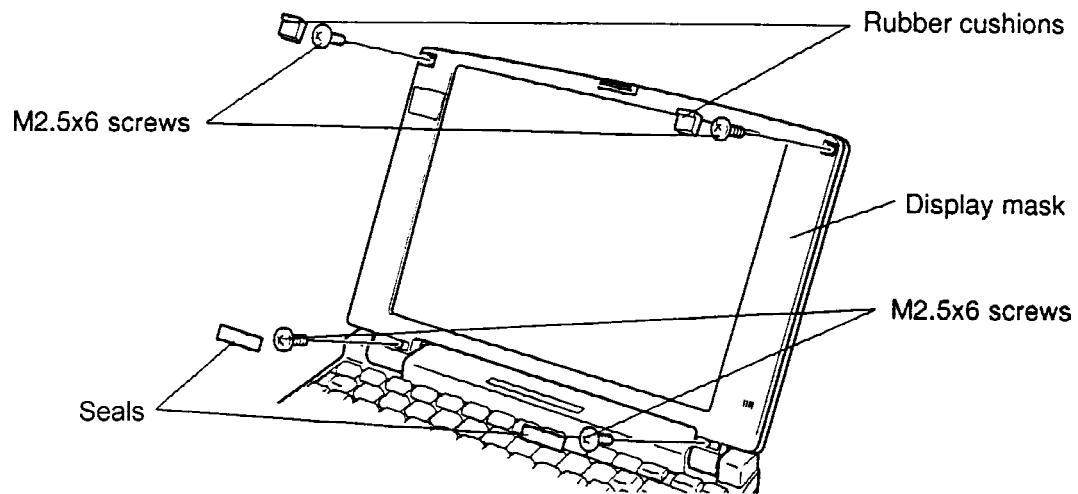

Figure 4-41 Removing the seals, cushions and screws

5. Carefully insert your fingers between the mask and the LCD panel and pry open the latches. Start with the **four latches** across the bottom of the display mask.
6. Continue releasing the mask along the **sides (four latches on each side)** and at the top (**four latches**).

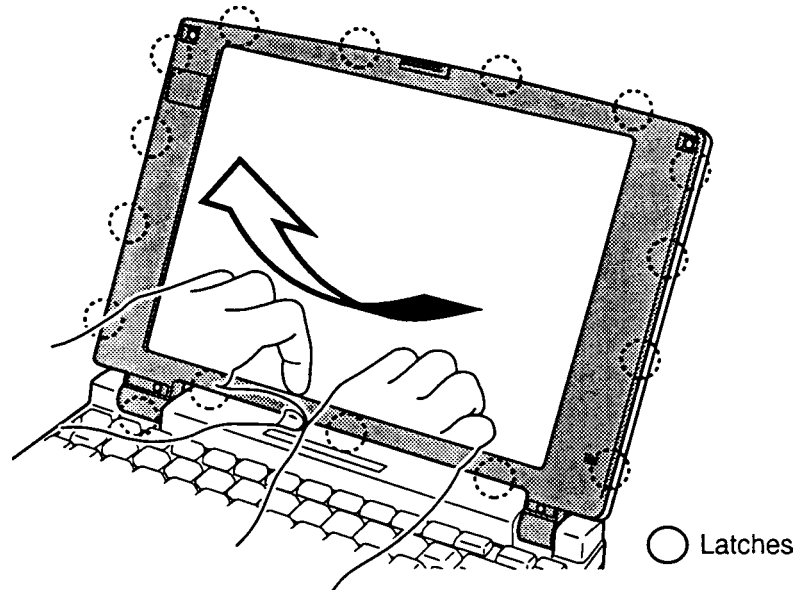

Figure 4-42 Removing the display mask

Installing the Display Mask

To install the display mask, follow the steps below and refer to Figures 4-42 and 4-41.

1. Set the **display mask** in place and secure the latches beginning with **four latches** at the top of the display mask.
2. Continue along the sides (**four latches** on each side) and bottom of the display (**four latches**).

NOTE: Support the back of the display with your hand when you secure the screws.

3. Secure the display mask with **four M2.5x6 screws**.
4. Attach the **two seals** and **two rubber cushions** to cover the screws.
5. Install the optional PC card, optional memory card and battery pack as described in Sections 4.4, 4.3, and 4.2.

4.17 Fluorescent Lamp (FL) Inverter Board (TFT)

Removing the FL Inverter Board (TFT)

To remove the FL inverter board, follow the steps below and refer to Figure 4-43.

1. Turn off power to the computer. Disconnect the AC power cable and all external cables connected to the computer.
2. Remove the battery pack, optional PC card, optional memory module and display mask as described in Sections 4.2, 4.3, 4.4, and 4.16.

NOTE: Be sure to support the back of the display with your hand.

3. Remove **two M2.5x6 screws** securing the **FL inverter board**. The screw on the left also secures the ground cable.
4. Remove the tape and disconnect the **FL inverter cable** from **CN1** and the **FL cable** from **CN2** on the **FL inverter board**. Lift the board out.

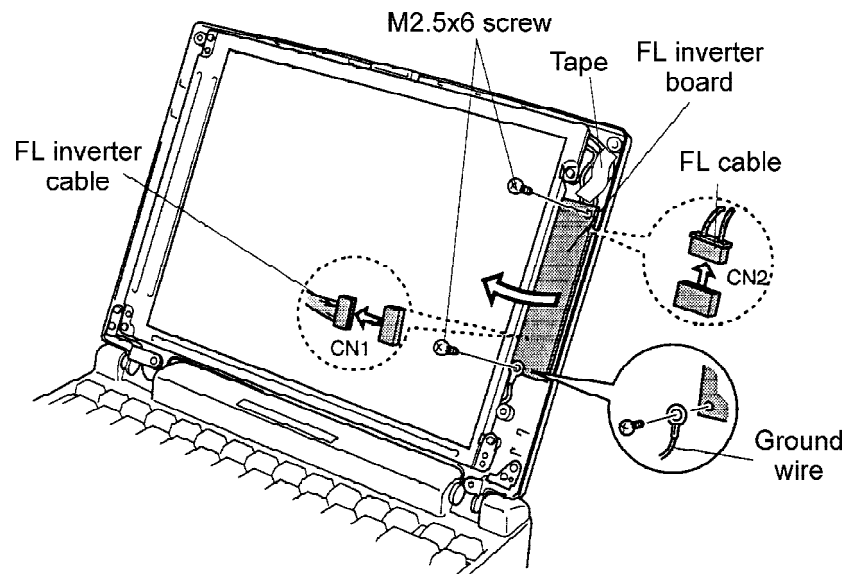

Figure 4-43 Removing the FL inverter board (TFT)

Installing the FL Inverter Board (TFT)

To install the FL inverter board, follow the steps below and refer to Figure 4-43.

1. Connect the **FL inverter cable** to **CN1** and the **FL cable** to **CN2** on the **FL inverter board**.
2. Replace the tape.
3. Seat the **FL inverter board**.

***NOTE:** Be sure to support the back of the display with your hand.*

4. Secure the **FL inverter board** with **two M2.5x6 screws**. Be sure that the left screw secures the ground cable.
5. Install the display mask, optional memory card, optional PC card, and battery pack as described in Sections 4.16, 4.4, 4.3, and 4.2.

4.18 Fluorescent Lamp (FL) Inverter Board (DSTN)

Removing the FL Inverter Board (DSTN)

To remove the FL inverter board, follow the steps below and refer to Figure 4-44.

1. Turn off power to the computer. Disconnect the AC power cable and all external cables connected to the computer.
2. Remove the battery pack, optional PC card, optional memory module, and display mask as described in Sections 4.2, 4.3, 4.4, and 4.16.

NOTE: Support the back of the display with your hand when you remove the screws.

3. Remove **two M2.5x6 screws** securing the **FL inverter board**. The left screw also secures the ground cable.
4. Remove **one M2.5x6 screw** securing the **contrast control board**.
5. Disconnect the **contrast control cable** from the **contrast control board**.
6. Remove tape and disconnect the **FL inverter cable** from **CN1** and the **FL cable** from **CN2** on the **FL inverter board**.
7. Lift the board out.

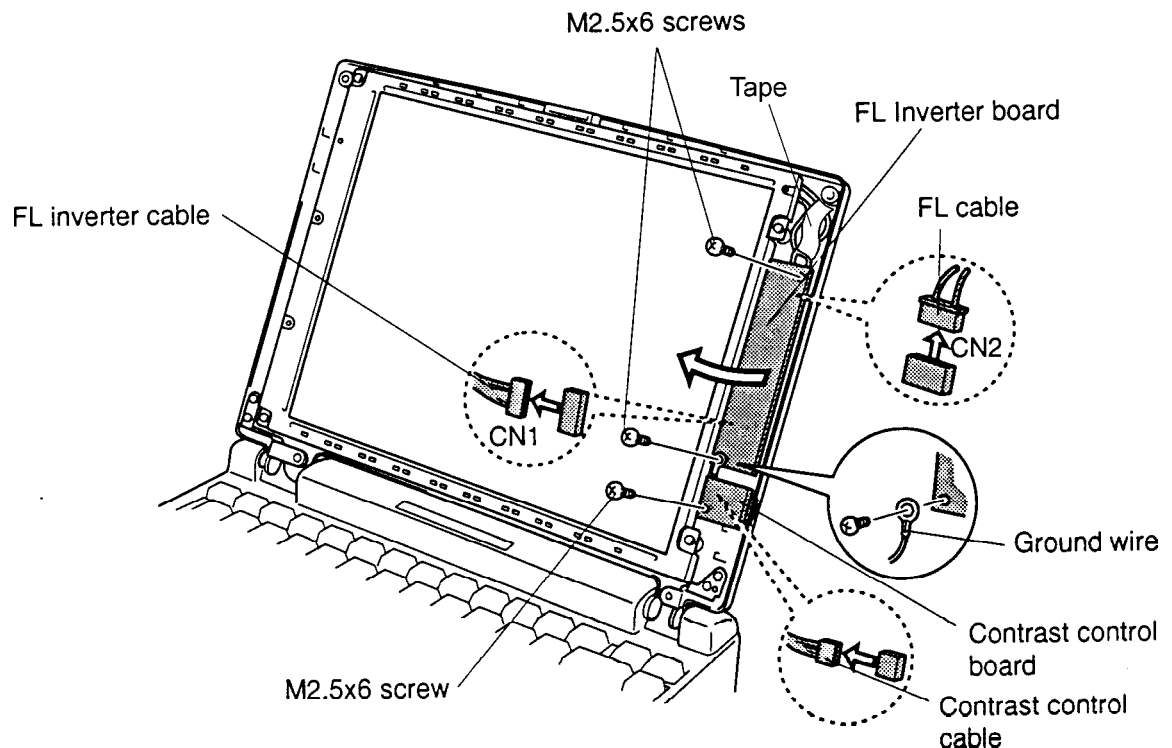

Figure 4-44 Removing the FL inverter board (DSTN)

Installing the FL Inverter Board (DSTN)

To install the FL inverter board, follow the steps below and refer to Figure 4-44.

1. Seat the **FL inverter board**.
2. Connect the **FL inverter cable** to **CN1** and the **FL cable** to **CN2** on the FL inverter board.
3. Secure the **FL inverter board** with **two M2.5x6 screws**. Be sure the contrast control wheel is fitted into its opening in the case.
4. Connect the **contrast control cable** to the **contrast control board**.

***NOTE:** Support the back of the display with your hand when you secure the screws.*

5. Secure the **contrast control board** with **one M2.5x6 screw**. Be sure the left screw secures the ground cable.
6. Replace the tape on the FL inverter cable.
7. Install the display mask, optional memory card, optional PC card and battery pack as described in Sections 4.16, 4.4, 4.3, and 4.2.

4.19 Liquid Crystal Display (LCD) Module (TFT)

Removing the LCD Module (TFT)

To remove the LCD module, follow the steps below and refer to Figures 4-45 and 4-46.

1. Turn off the power to the computer. Disconnect the AC power cord and all external cables connected to the computer.
2. Remove the battery pack, optional memory module, optional PC card, display mask and FL inverter board as described in Sections 4.2, 4.3, 4.4, 4.16, and 4.17.

NOTE: Support the back of the display with your hand when you remove the screws.

3. Remove **four M2.5x6 screws** securing the **LCD module** to the LCD cover. The screw at the lower left corner also secures the **ground cable**.

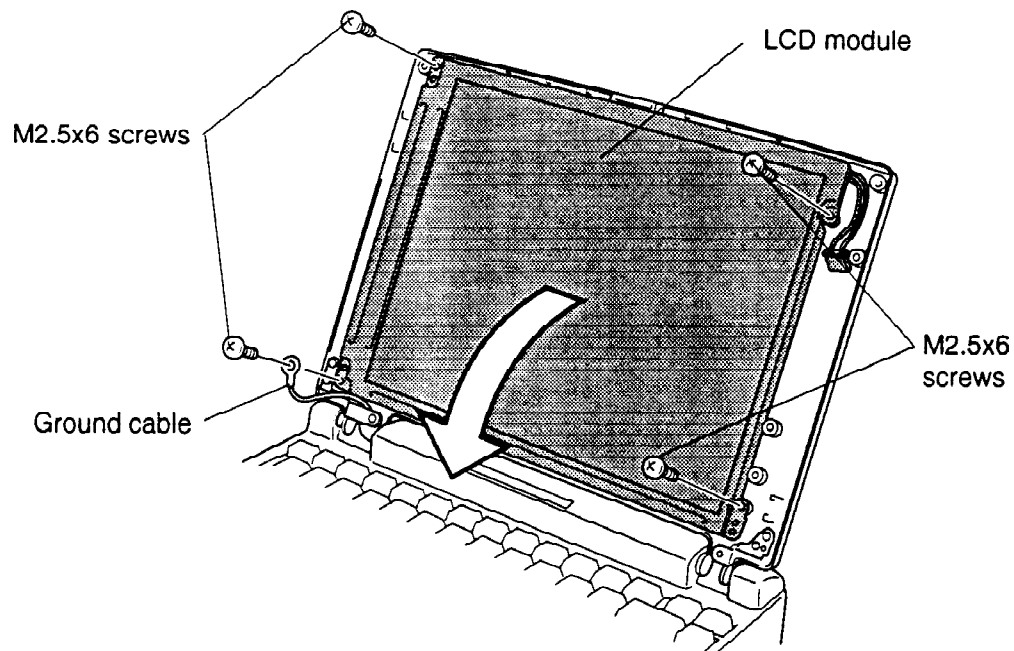

Figure 4-45 Removing the LCD module screws (TFT)

NOTE: Metal edges on the LCD module are sharp, so be careful not to cut yourself.

4. Carefully rotate the **LCD module** out of the LCD cover and lay it on the keyboard.

5. Disconnect the flexible cable from the LCD module and disconnect **four display cables** from **PJ2, PJ3, PJ4, and PJ5** on the **flexible cable**.
6. Remove the **shielded tape** securing the display cables to the LCD cover.

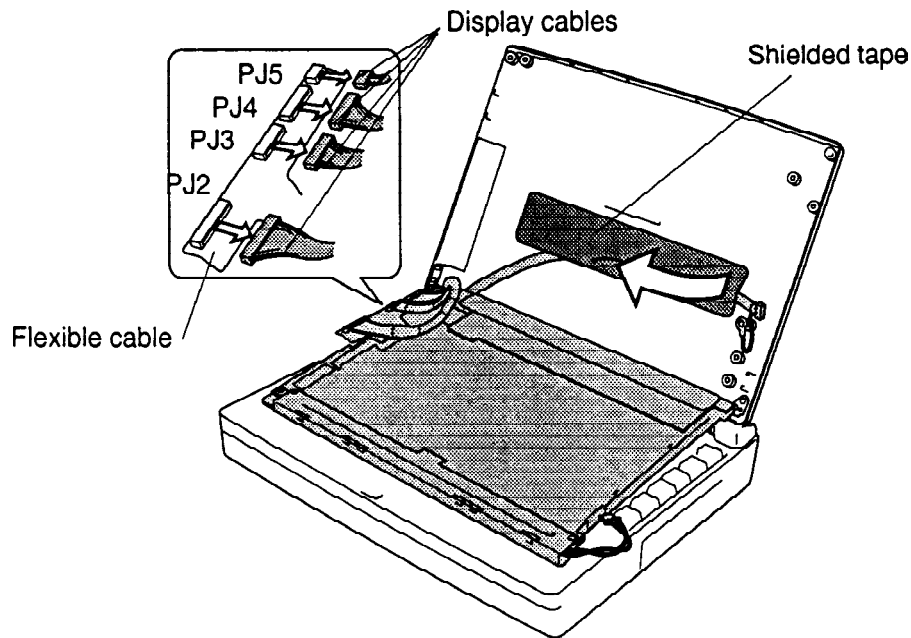

Figure 4-46 Removing the LCD module (TFT)

Installing the LCD Module (TFT)

To install the LCD module, follow the steps below and refer to Figures 4-46 and 4-45.

1. Secure the display cable to the LCD cover with shielded tape.
2. Connect the **display cables** to **PJ2, PJ3, PJ4, and PJ5** on the **flexible cable** and connect the flexible cable to the LCD module.
3. Carefully rotate the LCD module into the LCD cover. Be sure the flexible cable fits securely into the clear plastic protector.

NOTE: Support the back of the display with your hand when you secure the screws.

4. Secure **four M2.5x6 screws** with **ground cable** on the **LCD module**. Make sure the ground cable is secured at the lower left corner.
5. Install the FL inverter board, display mask, optional memory module, optional PC card, and battery pack as described in Sections 4.17, 4.16, 4.4, 4.3, and 4.2.

4.20 Liquid Crystal Display (LCD) Module (DSTN)

Removing the LCD Module (DSTN)

To remove the LCD module, follow the steps below and refer to Figures 4-47 and 4-48.

1. Turn off the power to the computer. Disconnect the AC power cord and all external cables connected to the computer.
2. Remove the battery pack, optional memory module, optional PC card, display mask and FL inverter board as described in Sections 4.2,4.3, 4.4, 4.16, and 4.18.

NOTE: Support the back of the display with your hand when you remove the screws.

3. Remove **four M2.5x6 screws** securing the **LCD module** to the LCD cover. The screw at the lower left corner also secures the **ground cable**.

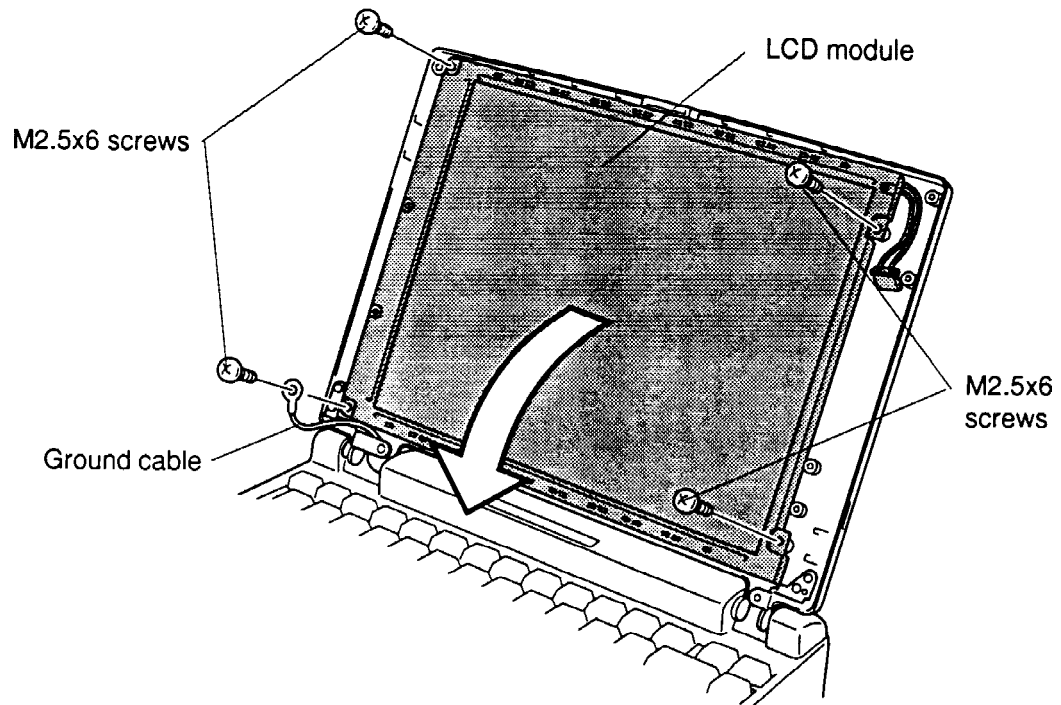

Figure 4-47 Removing the LCD module screws (DSTN)

NOTE: Metal edges on the LCD module are sharp, so be careful not to cut yourself.

4. Carefully rotate the **LCD module** out of the LCD cover and lay it on the keyboard.
5. Disconnect the flexible cable from CN IN on the LCD module, then disconnect **three display cables** from **PJ2, PJ3, and PJ4** on the **flexible cable**.

6. Remove the **shielded tape** securing the display cables to the LCD cover.

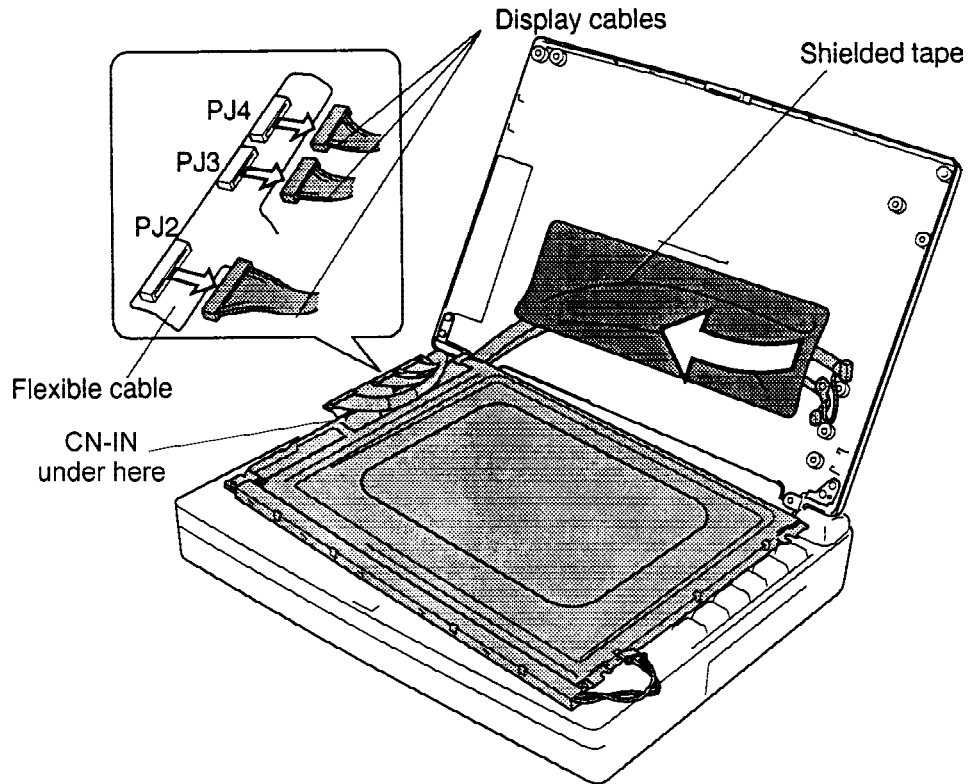

Figure 4-48 Removing the LCD module (DSTN)

Installing the LCD Module (DSTN)

To install the LCD module, follow the steps below and refer to Figures 4-48 and 4-47.

1. Secure the display cable to the LCD cover with shielded tape.
2. Connect the **flexible cable** to **CN-IN** on the **LCD module**.
3. Connect the **display cables** to **PJ2**, **PJ3**, and **PJ4** on the **flexible cable**.
4. Carefully rotate the LCD module into the LCD cover. Be sure the flexible cable fits into the plastic protector.

NOTE: Support the back of the display with your hand when you secure the screws.

5. Secure **four M2.5x6 screws** on the **LCD module**. Make sure the ground cable is secured at the lower left corner.
6. Install the FL inverter board, display mask, optional memory module, optional PC card and battery pack as described in Sections 4.18, 4.16, 4.4, 4.3, and 4.2.

4.21 FL (TFT)

CAUTION: When you remove the FL, be careful not to let any dust or other foreign matter contaminate the LCD panel. Any contamination can affect the performance of the unit.

Removing the FL (TFT)

To remove the FL, follow the steps below and refer to Figures 4-49 and 4-50.

1. Turn off the power to the computer. Disconnect the AC power cord and all external cables connected to the computer.
2. Remove the battery pack, optional memory module, optional PC card, display mask, FL inverter board and LCD module as described in Sections 4.2, 4.3, 4.4, 4.16, 4.17, and 4.19.
3. Place the **FL** face down and remove **two M2x3.5 silver screws**.
4. Use a thin object to release **two latches** and remove the gold protective tape.
5. Slide the metal cover to the left and remove it.
6. Remove **two M2x5.5 silver screws**, **two M2x3.5 silver screws**, and **one M2x2.3 black screw** from the LCD PCB.
7. Remove the tape and disconnect the **LCD PCB** (connected by a flexible cable) from **CN2** on the LCD module.

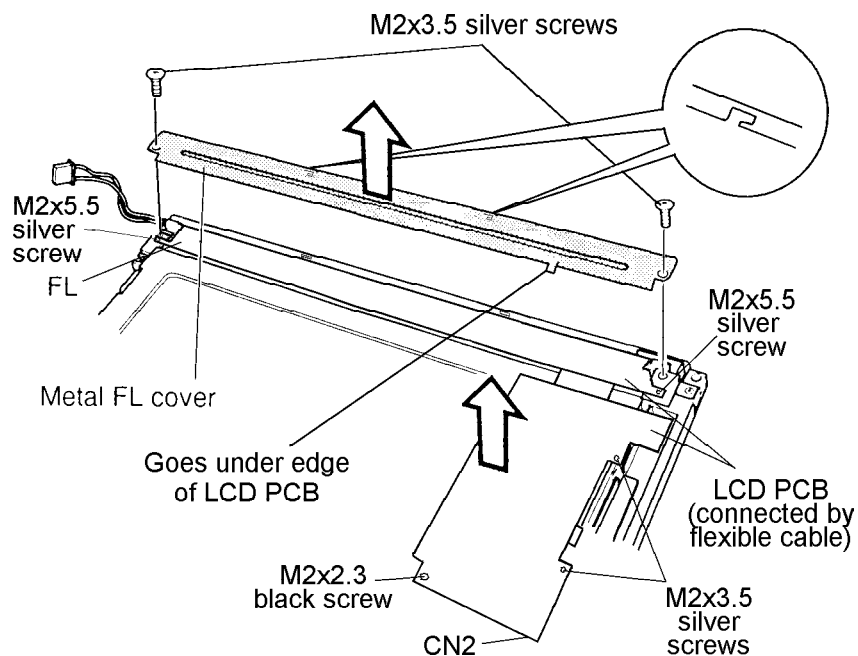

Figure 4-49 Accessing the FL (TFT)

8. Carefully rotate the two parts of the **LCD PCB** out so you can access the **FL**.
9. Remove the **white protective tape** securing the FL.
10. Pull back the **white plastic cover** and remove the **FL**. Be sure to note how the FL is threaded.

NOTE: Be extremely careful of the silver covering over the back of the screen, do not remove this covering.

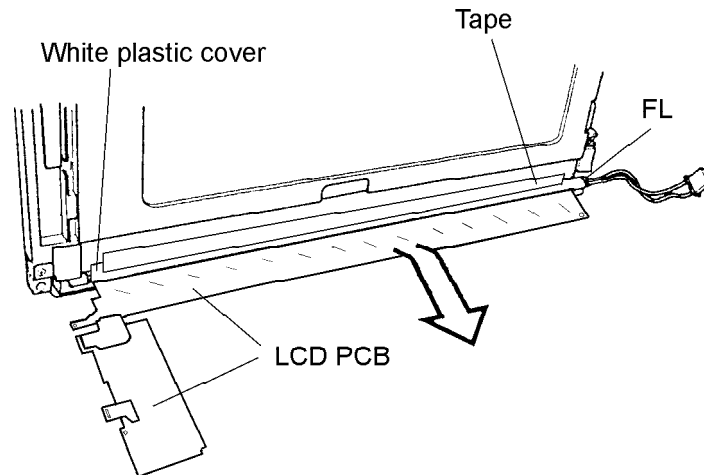

Figure 4-50 Removing the FL (TFT)

Installing the FL (TFT)

To install the FL, follow the steps below and refer to Figures 4-50 and 4-49.

1. Place the **FL** in the frame. Lift up the **white plastic cover** to route the FL cable.
2. Replace the **white protective tape** covering the FL.
3. Rotate the two parts of the **LCD PCB** (connected by a flexible cable) back into place and press firmly to connect the LCD PCB to **CN2** on the LCD module. Replace the tape.
4. Secure the LCD PCB with **one M2x2.3 black screw, two M2x3.5 silver screws, and two M2x5.5 silver screws**.
5. Seat the **metal FL cover**. Slide it to the right to secure the latches.
6. Be sure the extension on the metal cover is under the edge of the LCD PCB.
7. Secure **two M2x3.5 silver screws** and replace the gold protective tape.
8. Install the LCD module, FL inverter board, display mask, optional PC card, optional memory module and the battery pack as described in Sections 4.19, 4.17, 4.16, 4.4, 4.3, and 4.2.

4.22 FL (DSTN)

CAUTION: When you remove the FL, be careful not to let any dust or other foreign matter enter the LCD panel components. Any contamination can affect the performance of the unit.

Removing the FL (DSTN)

To remove the FL, follow the steps below. Refer to Figures 4-51 to 4-52.

1. Turn off the power to the computer. Disconnect the AC power cord and all external cables connected to the computer.
2. Remove the battery pack, optional memory module, optional PC card, display mask, FL inverter board and LCD module as described in Sections 4.2, 4.3, 4.4, 4.16, 4.18, and 4.20.
3. Turn the **LCD module** over and release **four latches** securing the **FL module** to its frame.
4. Remove **two M2x6 silver screws**.

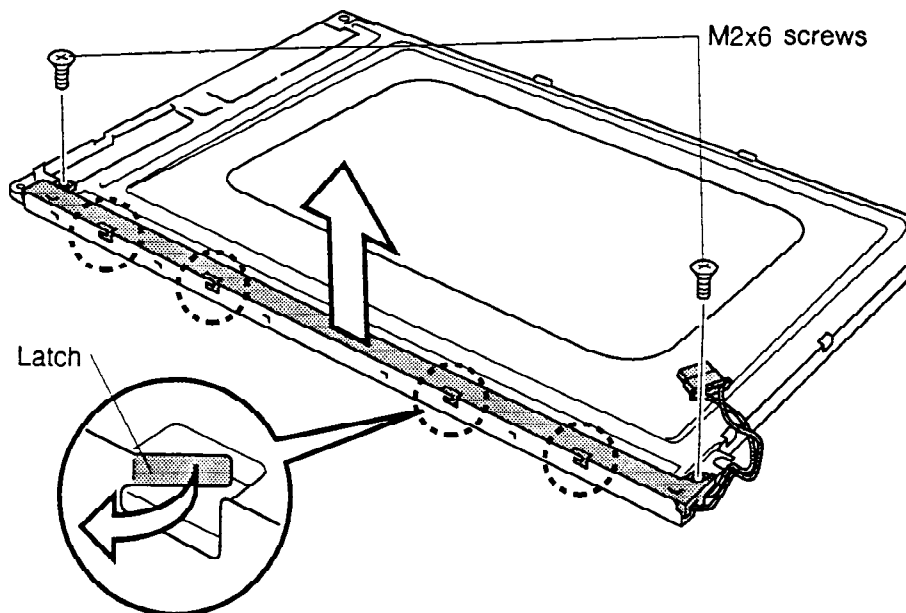

Figure 4-51 Removing the FL assembly (DSTN)

5. Lift the FL module out of the frame.

6. Carefully lift the FL out of the FL unit. The FL is fragile, be sure to not exert undue pressure which could cause it to snap.

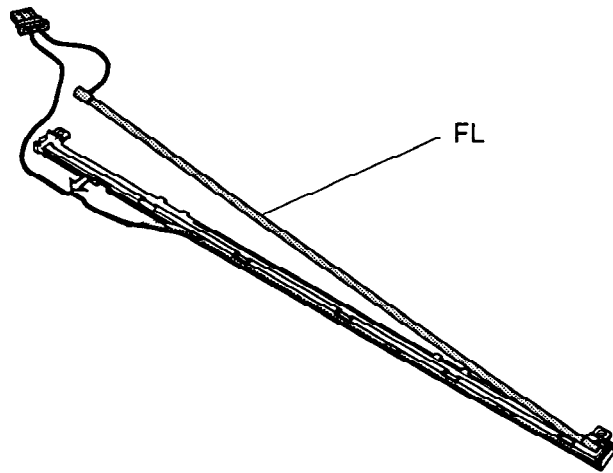

Figure 4-52 Removing the FL (DSTN)

Installing the FL (DSTN)

To install the FL, follow the steps below and refer to Figures 4-52 and 4-51.

1. Seat the **FL** and gently press it securely in place.
2. Secure **four latches**.
3. Secure **two M2x6 silver screws**.
4. Install the LCD module, FL inverter board, display mask, optional PC card, optional memory module and the battery pack as described in Sections 4.20, 4.18, 4.16, 4.4, 4.3, and 4.2.

4.23 Microphone

Removing the Microphone

To remove the microphone, follow the steps below and refer to Figure 4-53.

1. Turn off the power to the computer. Disconnect the AC power cord and all external cables connected to the computer.
2. Remove the battery pack, optional memory module, optional PC card, FDD or CD-ROM drive, HDD, keyboard, VGA board, sub-battery, RTC battery, top cover with display assembly, display mask, FL inverter board, LCD module and FL as described in Sections 4.2 through 4.22.
3. Lift out the **microphone**.

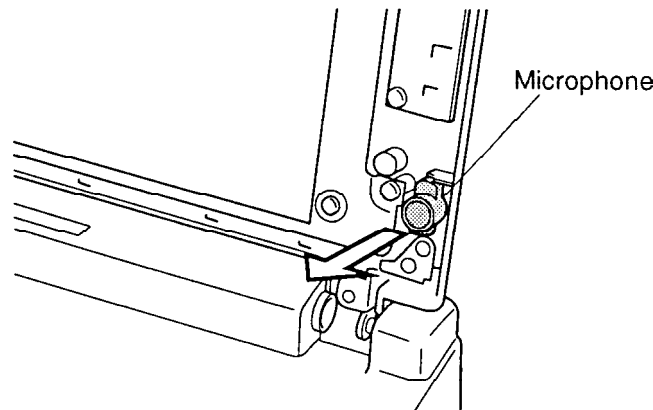

Figure 4-53 Removing the microphone

4. Carefully pull the **microphone cable** through the upper cover.

Installing the Microphone

To install the microphone, follow the steps below and refer to Figure 4-53.

1. Carefully route the **microphone cable** through the upper cover.
2. Seat the **microphone**.
3. Install the FL, LCD module, FL inverter board, display mask, top cover with display assembly, keyboard, optional memory module, optional PC card and battery pack as described in Sections 4.22 back through 4.2.

Appendix A Handling the LCD Module

Precautions for Handling the LCD Module

The LCD module can be easily damaged during assembly or disassembly. Observe the following precautions when handling the LCD module.

1. When installing the LCD module in the LCD cover, be sure to seat it so that it is properly aligned and maximum visibility of the display is maintained.

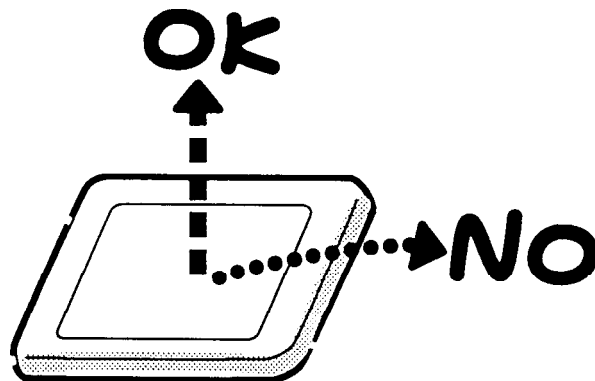

2. Be careful to align the holes at the four corners of the LCD module with the corresponding holes in the LCD cover before securing the module with screws. Do not force the module into place because stress can affect its performance.

Also, the panel's polarized surface is easily scarred, so be careful when handling it.



3. If the panel's surface gets dirty, wipe it with cotton or a soft cloth. If it is still dirty, try breathing on the surface to create a light condensate and wipe it again.

If the surface is very dirty, we recommend a CRT cleaning agent. Apply the agent to a cloth and then wipe the panel's surface. Do not apply cleanser directly to the panel.

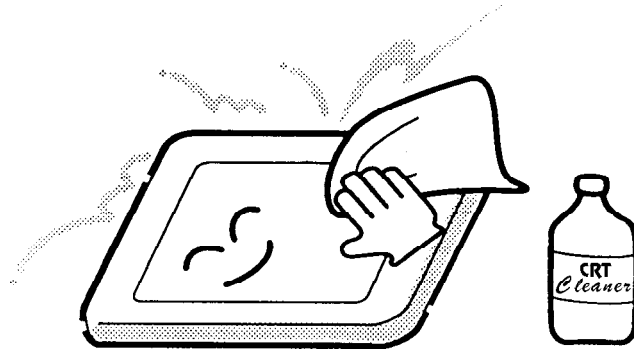

4. If water or other liquid is left on the panel's surface for a long period, it can change the screen's tint or stain it. Be sure to quickly wipe off any liquid.

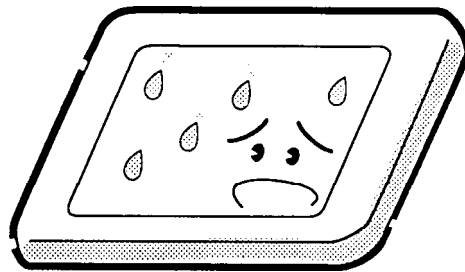

5. Glass is used in the panel, so be careful not to drop it or let it strike a hard object, which could cause breakage or cracks.

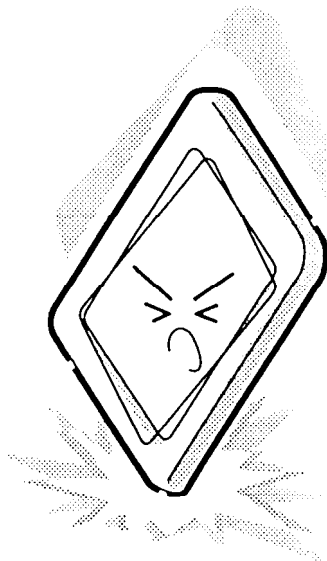

6. CMOS-LSI circuits are used in the module, so guard against damage from electrostatic discharge. Be sure to wear a wrist or ankle ground when handling the module.

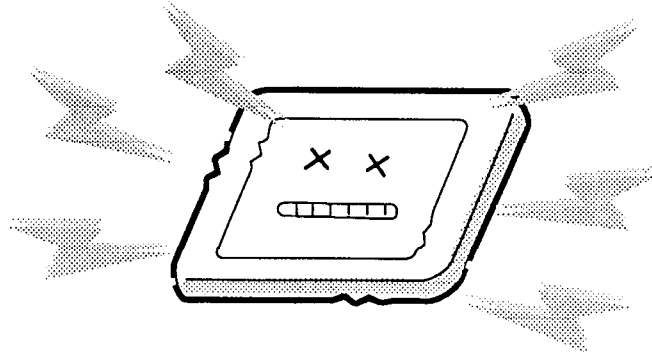

7. Do not expose the module to direct sunlight or strong ultraviolet rays for long periods.

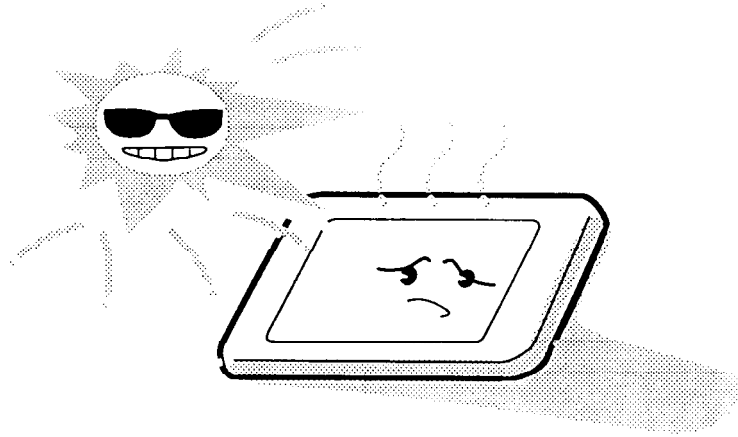

8. Do not store the module at temperatures below specifications. Cold can cause the liquid crystals to freeze, lose their elasticity or otherwise suffer damage.

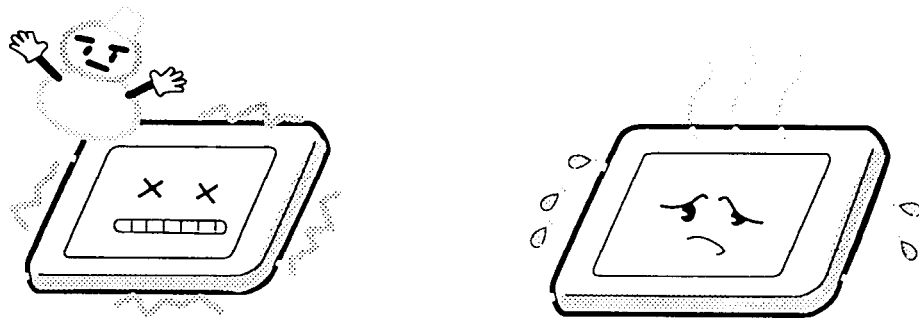

9. Do not disassemble the LCD module. Disassembly can cause malfunctions.

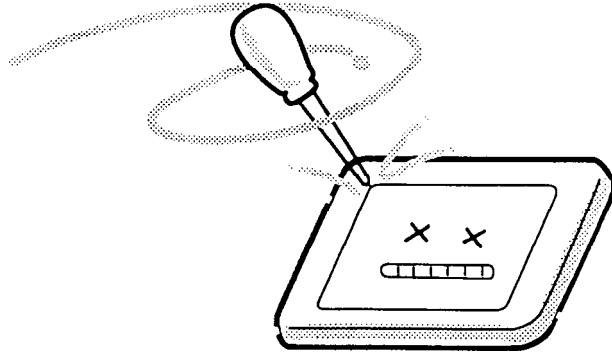

10. If you transport the module, do not use packing material that contains epoxy resin (amine) or silicon glue (alcohol or oxime). These materials can release gas that can damage the panel's polarization.

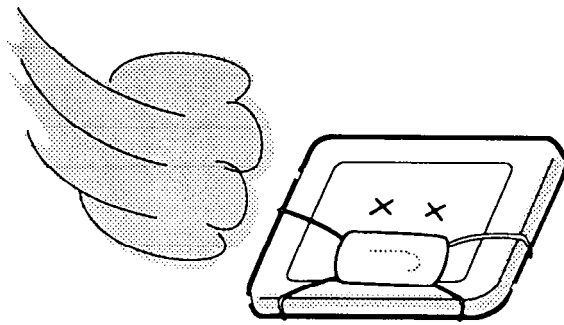

Appendix B Board Layout

B.1 System Board Front View

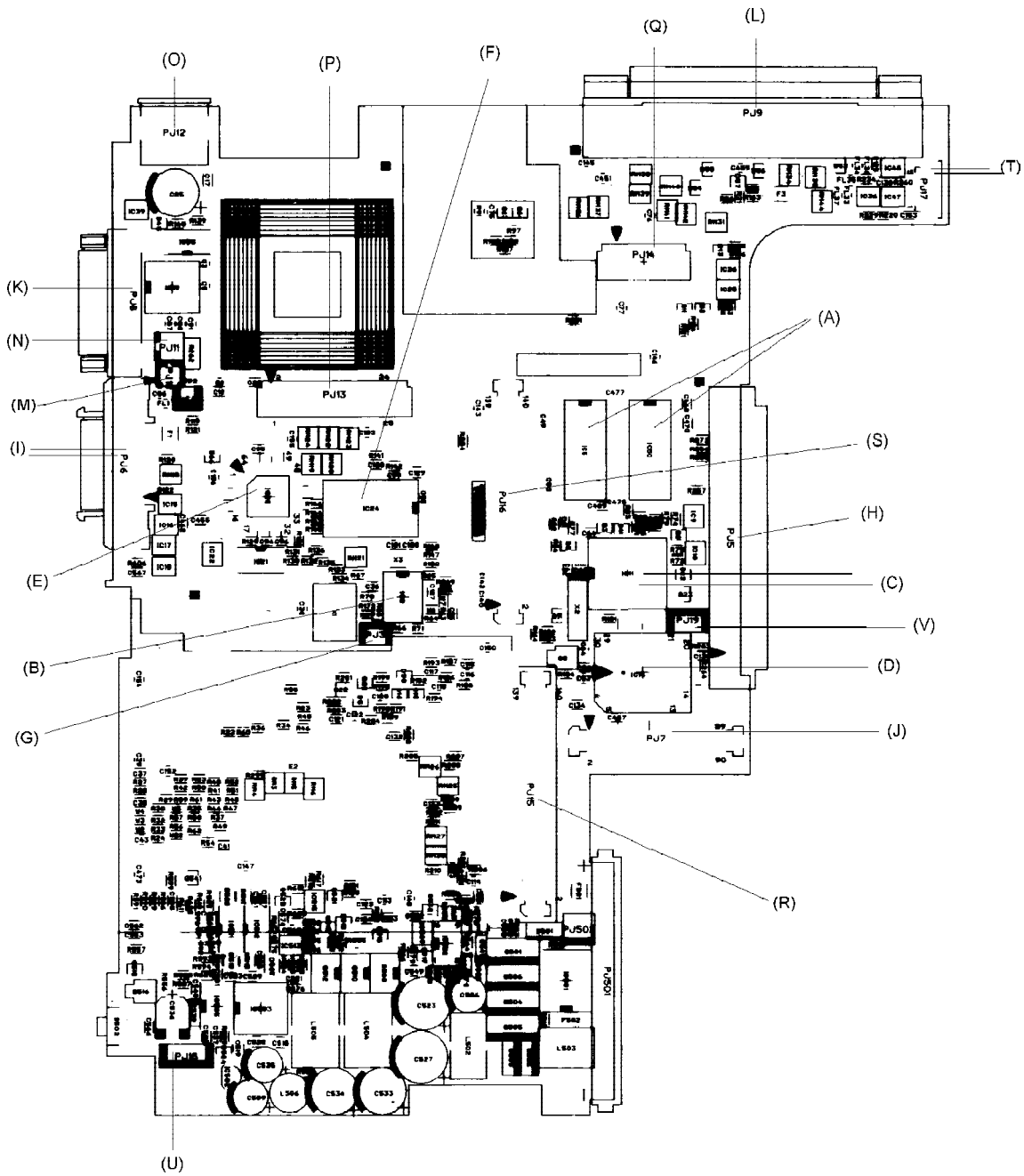

Figure B-1 Board layout (front)

B.2 System Board Back View

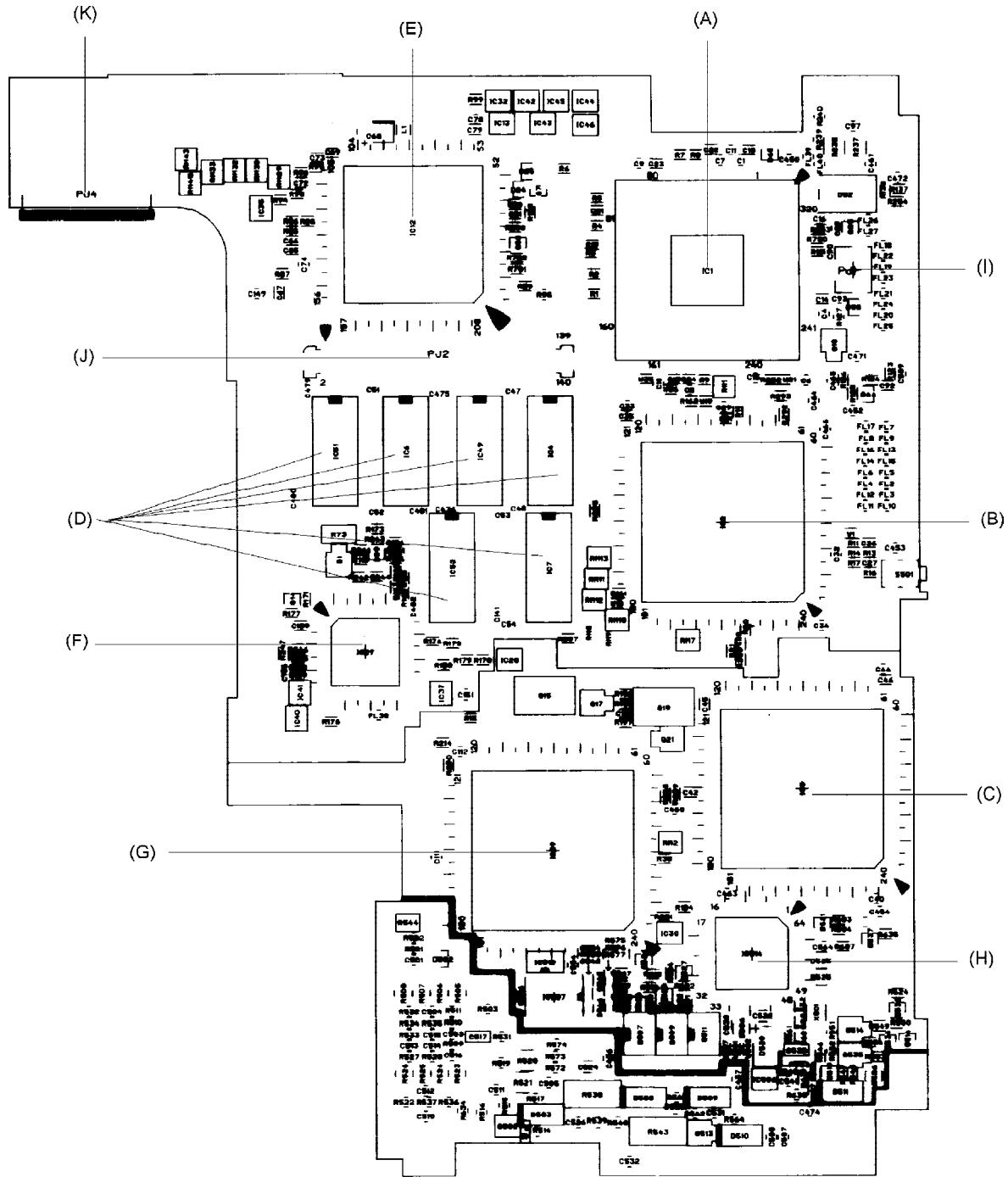

Figure B-2 Board layout (back)

Table B-1 System board ICs and connectors (front)

Mark	Number	Name
(A)	IC5 and 50	System Memory
(B)	IC8	System Clock
(C)	IC11	RTC Controller
(D)	IC14	BIOS ROM
(E)	IC20	Keyboard Controller
(F)	IC24	IPS Controller
(G)	PJ3	Ni-Mh RTC Battery Connector
(H)	PJ5	FDD/CD-ROM I/F Connector
(I)	PJ6	Ext. FDD Connector
(J)	PJ7	Sound HDD Connector
(K)	PJ8	ASYNC I/F Connector
(L)	PJ9	P-REP Connector
(M)	PJ10	Panel Close Sensor Connector
(N)	PJ11	Fan Connector
(O)	PJ12	Ext. Keyboard Connector
(P)	PJ13	Keyboard Connector
(Q)	PJ14	LED Connector
(R)	PJ15	PC Card Slot Connector
(S)	PJ16	VGA Connector
(T)	PJ17	IrDA Board Connector
(U)	PJ18	Sound Board Power I/F Connector
(V)	PJ19	CD Audio Connector

Table B-2 System board ICs and connectors (back)

Mark	Number	Name
(A)	IC1	CPU
(B)	IC2	SCPCNT GA
(C)	IC3	SISCNT GA
(D)	IC4,6,7,49, 51 and 52	System Memory
(E)	IC12	SI
(F)	IC27	I/O Controller GA
(G)	IC29	PC Card Controller GA
(H)	IC514	PS Microprocessor
(I)	PJ1	Thermistor Connector
(J)	PJ2	Exp.Memory Connector
(K)	PJ4	PRT/RGB I/F Connector

Table C-9 P-REP connector pin assignments (176-pin) (continued)

Pin No.	Signal Name	I/O	Pin No.	Signal Name	I/O
149	GND	—	150	SD02;110	I/O
151	SD08;110	I/O	152	SD10;110	I/O
153	GND	—	154	SD01;110	I/O
155	SD12;110	I/O	156	SD14;110	I/O
157	GND	—	158	IFTRK0;000	I
159	SLFDLD;100	—	160	IFRDAT;000	I
161	DSKCHG;000	I	162	IFWPRO;000	I
163	NC	—	164	IFHMED;000	I
165	GND	—	166	PRDT1;000	I
167	EXKBDT;100	I/O	168	EXKBCK;100	O
169	JOYR;000	I	170	JOYW;000	O
171	GND	—	172	HVPC	—
173	LOUTLM	O	174	LOURLP	O
175	LINLM	I	176	LINLP	I

C.10 PJ10 Panel Close Sensor Connector (2-pin)

Table C-10 Panel close sensor connector pin assignments (2-pin)

Pin No.	Signal Name	I/O	Pin No.	Signal Name	I/O
01	PNLOFF	I	02	GND	—

C.11 PJ11 Fan Connector (2-pin)

Table C-11 Fan connector pin assignments (2-pin)

Pin No.	Signal Name	I/O	Pin No.	Signal Name	I/O
01	VCC	—	02	GND	—

C.12 PJ12 Mouse Connector (6-pin)

Table C-12 Mouse connector pin assignments (6-pin)

Pin No.	Signal Name	I/O	Pin No.	Signal Name	I/O
01	MOUSE/KB_DATA	I/O	02	EXKBDT;100	I/O
03	GND	—	04	VCC	—
05	MOUSE/KB _CLOCKO	O	06	EXKBCK;100	O

Appendix D Keyboard Scan/Character Codes

Table D-1 Scan codes (set 1 and set 2)

Cap No.	Keytop	Code set 1		Code set 2		Note
		Make	Break	Make	Break	
01	‘ ~	29	A9	0E	F0 0E	
02	1 !	02	82	16	F0 16	
03	2 @	03	83	1E	F0 1E	
04	3 #	04	84	26	F0 26	
05	4 \$	05	85	25	F0 25	
06	5 %	06	86	2E	F0 2E	
07	6 ^	07	87	36	F0 36	
08	7 &	08	88	3D	F0 3D	*2
09	8 *	09	89	3E	F0 3E	*2
10	9 (0A	8A	46	F0 46	*2
11	0)	0B	8B	45	F0 45	
12	- _	0C	8C	4E	F0 4E	
13	= +	0D	8D	55	F0 55	
15	BkSp	0E	8E	66	F0 66	
16	Tab	0F	8F	0D	F0 0D	
17	Q	10	90	15	F0 15	
18	W	11	91	1D	F0 1D	
19	E	12	92	24	F0 24	
20	R	13	93	2D	F0 2D	
21	T	14	94	2C	F0 2C	
22	Y	15	95	35	F0 35	
23	U	16	96	3C	F0 3C	*2
24	I	17	97	43	F0 43	*2
25	O	13	98	44	F0 44	*2
26	P	19	99	4D	F0 4D	*2
27	[{	1A	9A	54	F0 54	
28] }	1B	9B	5B	F0 5B	
29(42)	\	2B	AB	5D	F0 5D	*5
30	Caps Lock	3A	BA	58	F0 58	
31	A	1E	9E	1C	F0 1C	
32	S	1F	9F	1B	F0 1B	
33	D	20	A0	23	F0 23	
34	F	21	A1	2B	F0 2B	
35	G	22	A2	34	F0 34	
36	H	23	A3	33	F0 33	
37	J	24	A4	3B	F0 3B	*2
38	K	25	A5	42	F0 42	*2
39	L	26	A6	4B	F0 4B	*2
40	; :	27	A7	4C	F0 4C	*2

Table D-1 Scan codes (set 1 and set 2) (continued)

Cap No.	Keytop	Code set 1		Code set 2		Note
		Make	Break	Make	Break	
41	' "	28	A8	52	F0 52	
43	Enter	1C	9C	5A	F0 5A	
44	Shift (L)	2A	AA	12	F0 12	
45	No.102 key	56	D6	61	F0 61	
46	Z	2C	AC	1A	F0 1A	
47	X	2D	AD	22	F0 22	
48	C	2E	AE	21	F0 21	
49	V	2F	AF	2A	F0 2A	
50	B	30	B0	32	F0 32	
51	N	31	B1	31	F0 31	
52	M	32	B2	3A	F0 3A	*2
53	, <	33	B3	41	F0 41	*2
54	. >	34	B4	49	F0 49	*2
55	/ ?	35	B5	4A	F0 4A	*2
57	Shift (R)	36	B6	59	F0 59	
58	Ctrl	1D	9D	14	F0 14	*3
60	Alt (L)	38	B8	11	F0 11	*3
61	Space	39	B9	29	F0 29	
62	ALT (R)	E0 38	E0 B8	E0 11	E0 F0 11	
75	Ins	E0 52	E0 D2	E0 70	E0 F0 70	*1
76	Del	E0 53	E0 D3	E0 71	E0 F0 71	*1
79	←	E0 4B	E0 CB	E0 6B	E0 F0 6B	*1
80	Home	E0 47	E0 C7	E0 6C	E0 F0 6C	*1
81	End	E0 4F	E0 CF	E0 69	E0 F0 69	*1
83	↑	E0 48	E0 C8	E0 75	E0 F0 75	*1
84	↓	E0 50	E0 D0	E0 72	E0 F0 72	*1
85	PgUp	E0 49	E0 C9	E0 7D	E0 F0 7D	*1
86	PgDn	E0 51	E0 D1	E0 7A	E0 F0 7A	*1
89	→	E0 4D	E0 CD	E0 74	E0 F0 74	*1
110	Esc	01	81	76	F0 76	

Table D-1 Scan codes (set 1 and set 2) (continued)

Cap No.	Keytop	Code set 1		Code set 2		Note
		Make	Break	Make	Break	
112	F1	3B	3B	05	F0 05	
113	F2	3C	BC	06	F0 06	
114	F3	3D	BD	04	F0 04	
115	F4	3E	BE	0C	F0 0C	
116	F5	3F	BF	03	F0 03	
117	F6	40	C0	0B	F0 0B	
118	F7	41	C1	83	F0 83	
119	F8	42	C2	0A	F0 0A	
120	F9	43	C3	01	F0 01	
121	F10	44	C4	09	F0 09	
122	F11	57	D7	78	F0 78	*3
123	F12	58	D8	07	F0 07	*3
124	PrintSc	*6	*6	*6	*6	*6
126	Pause	*7	*7	*7	*7	*7
202	Fn	—	—	—	—	*4

Notes:

- 1* Scan codes differ by mode.
- 2* Scan codes differ by overlay function.
- 3* Combination with **Fn** key makes different codes.
- 4* **Fn** key does not generate a code by itself.
- 5* This key corresponds to key No. 42 in 102-key model.
- 6* Refer to table D-6, scan codes with **Ctrl** key.
- 7* Refer to table D-7, scan codes with **Alt** key.

Table D-2 Scan codes with left Shift key

Cap No.	Key top	Code set 1		Code set 2	
		Make	Break	Make	Break
75	INS	E0 AA E0 52	E0 D2 E0 2A	E0 F0 12 E0 70	E0 F0 70 E0 12
76	DEL	E0 AA E0 53	E0 D3 E0 2A	E0 F0 12 E0 71	E0 F0 71 E0 12
79	←	E0 AA E0 4B	E0 CB E0 2A	E0 F0 12 E0 6B	E0 F0 6B E0 12
80	Home	E0 A E0 47	E0 C7 E0 2A	E0 F0 12 E0 6C	E0 F0 6C E0 12
81	End	E0 AA E0 4F	E0 CF E0 2A	E0 F0 12 E0 69	E0 F0 69 E0 12
83	↑	E0 AA E0 48	E0 C8 E0 2A	E0 F0 12 E0 75	E0 F0 75 E0 12
84	↓	E0 AA E0 50	E0 D0 E0 2A	E0 F0 12 E0 72	E0 F0 72 E0 12
85	PgUp	E0 AA E0 49	E0 C9 E0 2A	E0 F0 12 E0 7D	E0 F0 7D E0 12
86	PgDn	E0 AA E0 51	E0 D1 E0 2A	E0 F0 12 E0 7A	E0 F0 7A E0 12
89	→	E0 AA E0 4D	E0 CD E0 2A	E0 F0 12 E0 74	E0 F0 74 E0 12

Note: The table above shows scan codes with the left **Shift** key. In combination with the right **Shift** key, scan codes are changed as below:

	With left Shift	With right Shift
Set 1	E0 AA	E0 B6
	E0 2A	E0 36
Set 2	E0 F0 12	E0 F0 59
	E0 12	E0 59

Table D-3 Scan codes in Numlock mode

Cap No.	Key top	Code set 1		Code set 2	
		Make	Break	Make	Break
75	INS	E0 2A E0 52	E0 02 E0 AA	E0 12 E0 70	E0 F0 70 E0 F0 12
76	DEL	E0 2A E0 53	E0 D3 E0 AA	E0 12 E0 71	E0 F0 71 E0 F0 12
79	←	E0 2A E0 4B	E0 CB E0 AA	E0 12 E0 6B	E0 F0 6B E0 F0 12
80	Home	E0 2A E0 47	E0 C7 E0 AA	E0 12 E0 6C	E0 F0 6C E0 F0 12
81	End	E0 2A E0 4F	E0 CF E0 AA	E0 12 E0 69	E0 F0 69 E0 F0 12
83	↑	E0 2A E0 48	E0 C8 E0 AA	E0 12 E0 75	E0 F0 75 E0 F0 12
84	↓	E0 2A E0 50	E0 D0 E0 AA	E0 12 E0 72	E0 F0 72 E0 F0 12
85	PgUp	E0 2A E0 49	E0 C9 E0 AA	E0 12 E0 7D	E0 F0 7D E0 F0 12
86	PgDn	E0 2A E0 51	E0 D1 E0 AA	E0 12 E0 7A	E0 F0 7A E0 F0 12
89	→	E0 2A E0 4D	E0 CD E0 AA	E0 12 E0 74	E0 F0 74 E0 F0 12

Table D-4 Scan codes with Fn key

Cap No.	Keytop	Code set 1		Code set 2		
		Make	Break	Make	Break	
43	ENT	E0 1C	E0 9C	E0 5A	E0 F0 5A	
58	CTRL	E0 1D	E0 9D	E0 14	E0 F0 14	
60	LALT	E0 38	E0 B8	E0 11	E0 F0 11	
121	ARROW	05	C5	77	F0 77	
122	NUMERIC	05	C5	7E	F0 7E	

Table D-5 Scan codes in overlay mode

Cap No.	Keytop	Code set 1		Code set 2		
		Make	Break	Make	Break	
08	7 (7)	47	C7	6C	F0 6C	
09	8 (8)	48	C8	75	F0 75	
10	9 (9)	49	C9	7D	F0 7D	
11	0 (*)	37	B7	7C	F0 7C	
23	U (4)	4B	CB	6B	F0 6B	
24	I (5)	4C	CC	73	F0 73	
25	O (6)	4D	CD	74	F0 74	
26	P (-)	4A	CA	7B	F0 7B	
37	J (1)	4F	CF	69	F0 69	
38	K (2)	50	D0	72	F0 72	
39	L (3)	51	D1	7A	F0 7A	
40	; (+)	4E	CE	79	F0 79	
52	M (0)	52	D2	70	F0 70	
53	, (,)	33	B3	41	F0 41	
54	(.)	53	D3	71	F0 71	
55	/ (/)	E0 35	E0 B5	40 4A	E0 F0 4A	

Table D-6 Scan codes with Ctrl key

Key top	Shift	Code set 1		Code set 2					
		Make	Break	Make	Break				
Prt Sc	Common	E0 2A	E0 37	E0 B7	E0 AA	E0 12	E0 7C	E0 F0 7C	E0 F0 12
	Ctrl*	E0 37		E0 B7		E0 7C		E0 F0 7C	
	Shift*	E0 37		E0 B7		E0 7C		E0 F0 7C	
	Alt*	54		D4		84		F0 B4	

Table D-7 Scan codes with Alt key

Key top	Shift	Code set 1						Code set 2							
		Make						Make							
Pause	Common	E1	ID	45	E1	SD	C5	E1	14	77	E1	F0	14	F0	77
	Ctrl*	E0	46	E0	C6	E0	7E	E0	F0	7E					

*: This key generates only make codes.

Appendix E Key Layouts

E.1 United States (US) Keyboard

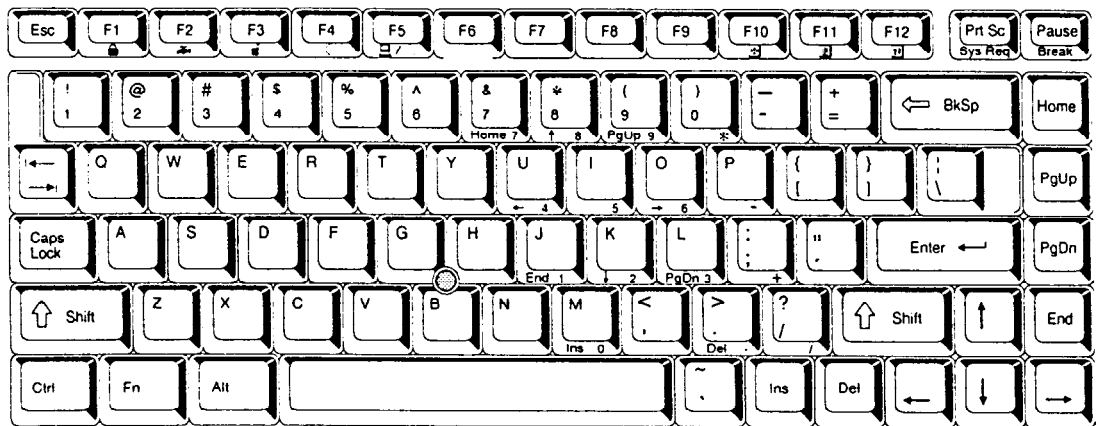

Figure E-1 US keyboard

E.2 United Kingdom (UK) Keyboard

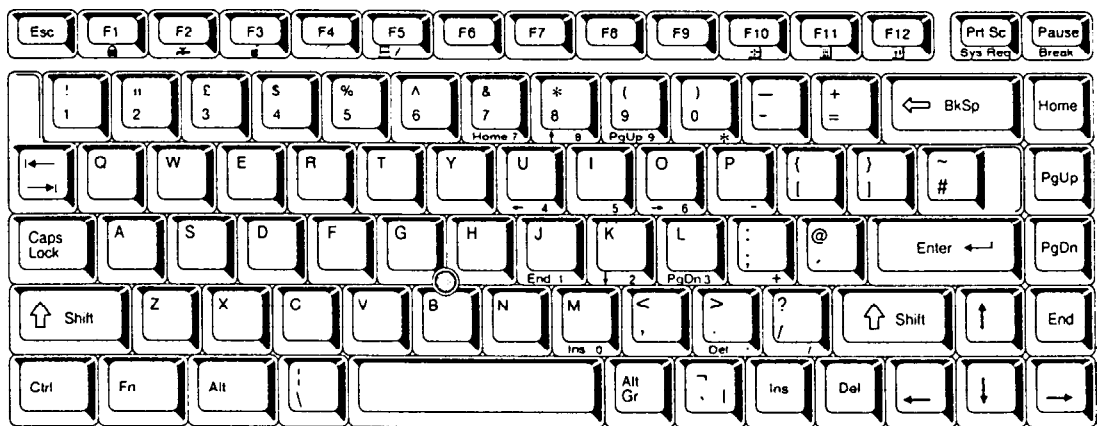

Figure E-2 UK keyboard

E.3 German (GR) Keyboard

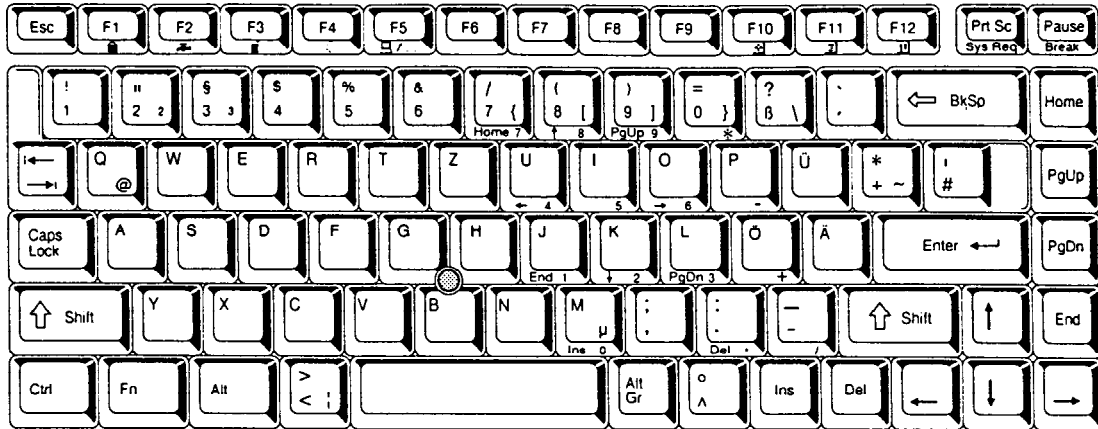

Figure E-3 GR keyboard

E.4 French (FR) Keyboard

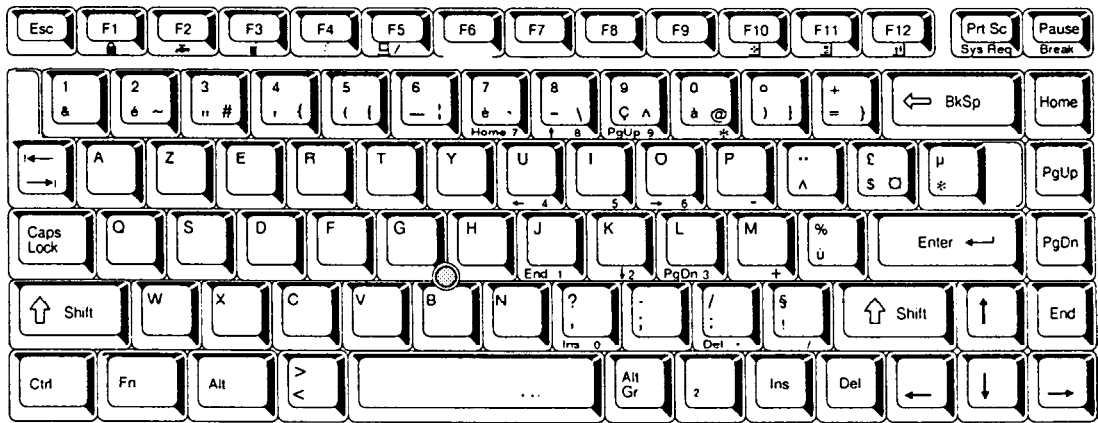

Figure E-4 FR keyboard

E.5 Spanish (SP) Keyboard

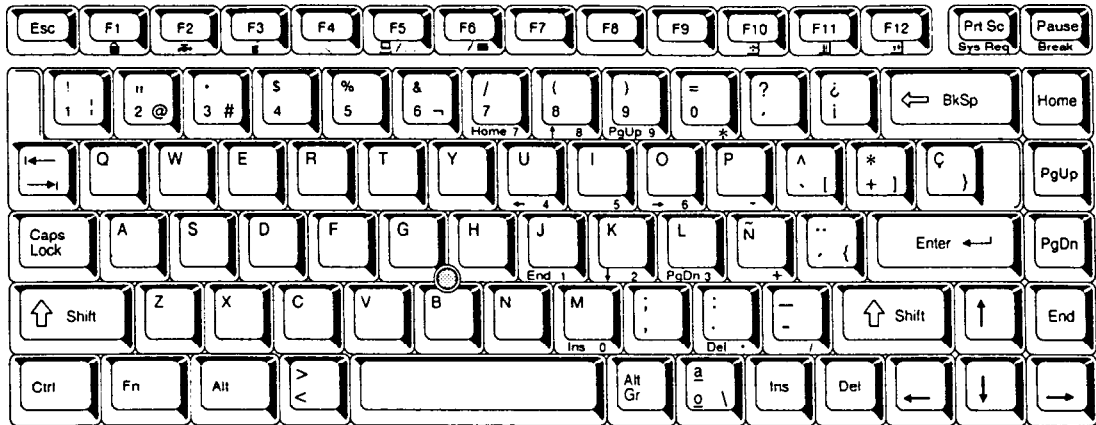

Figure E-5 SP keyboard

E.6 Italian (IT) Keyboard

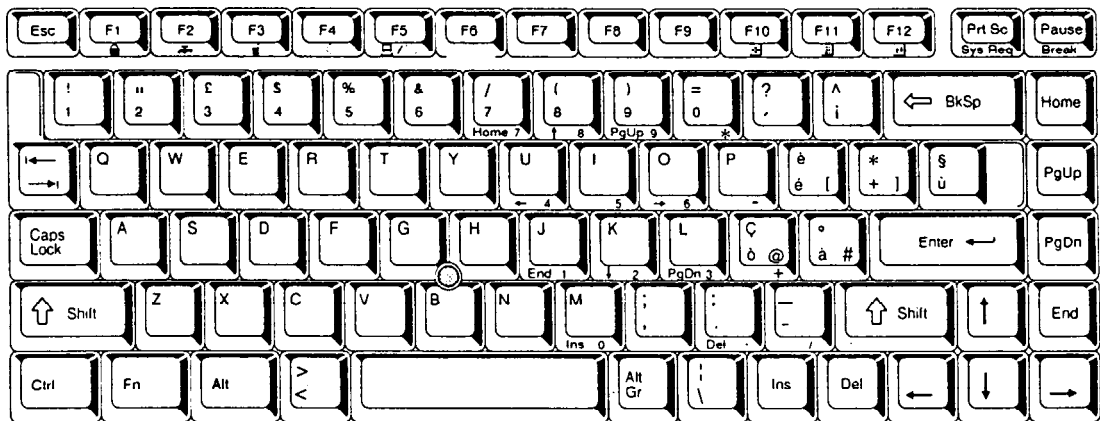

Figure E-6 IT keyboard

E.7 Scandinavian (SC) Keyboard

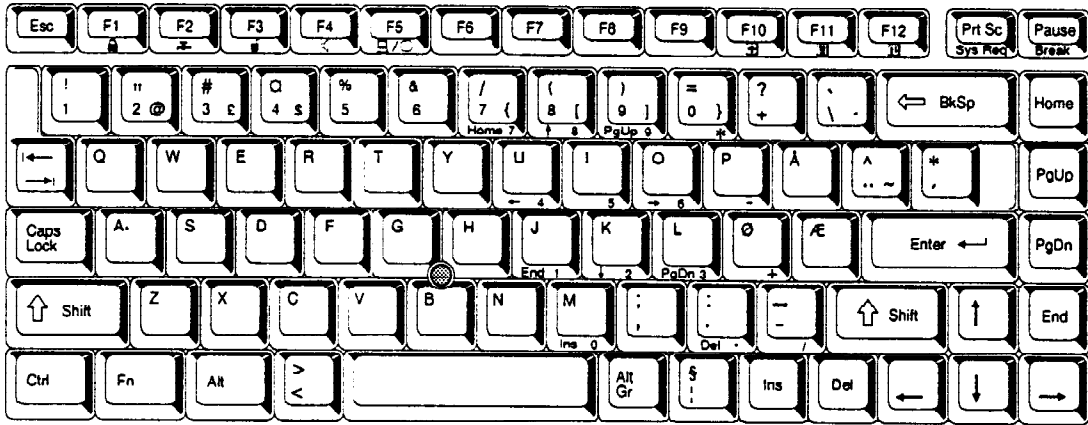

Figure E-7 SC keyboard

E.8 Swiss-German (SL) Keyboard

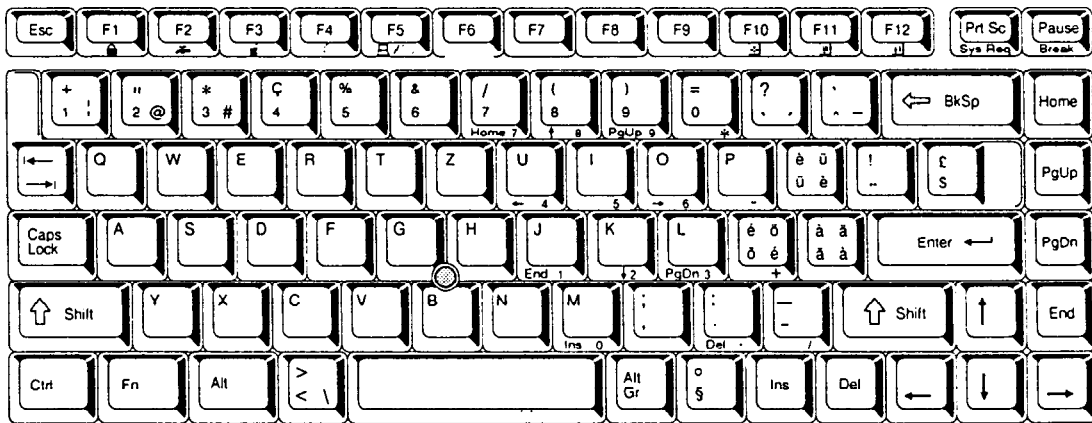

Figure E-8 SL keyboard

Appendix F Wiring Diagrams

F.1 Printer Wraparound Connector

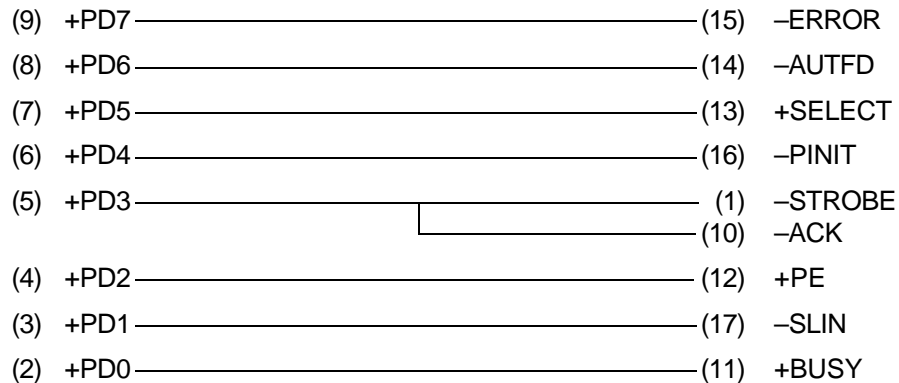

Figure F-1 Printer wraparound connector

F.2 RS-232-C Wraparound Connector

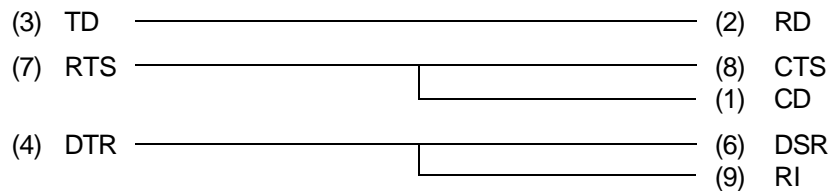

Figure F-2 RS-232-C wraparound connector

F.3 RS-232-C Direct Cable (9-Pin to 9-Pin)

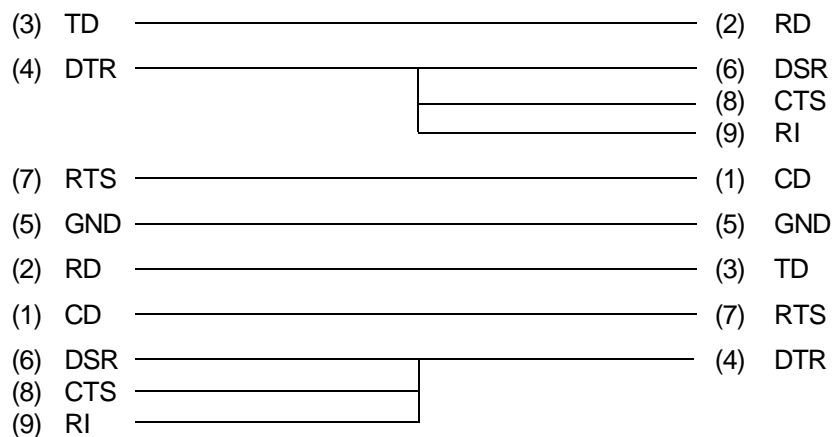

Figure F-3 RS-232-C direct cable (9-pin to 9-pin)

F.4 RS-232-C Direct Cable (9-Pin to 25-Pin)

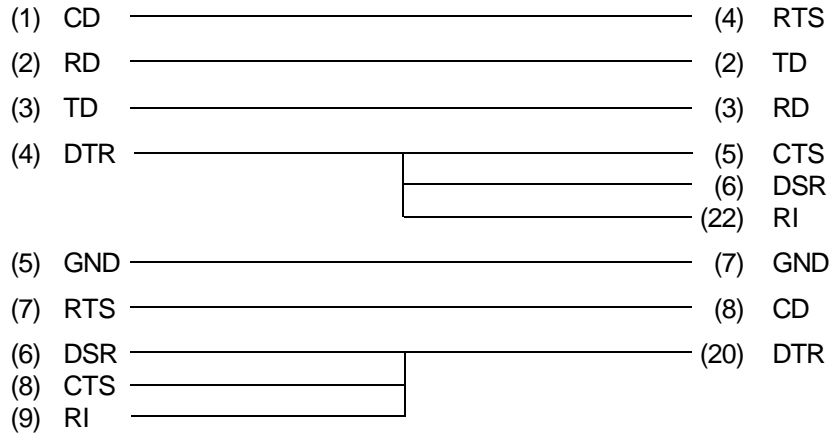

Figure F-4 RS-232-C direct cable (9-pin to 25-pin)

Appendix G BIOS Rewrite Procedures

This Appendix explains how to rewrite the system BIOS program when you update the system BIOS.

Tools

To rewrite the BIOS, you need the following tool:

- ❑ BIOS rewrite disk for the 430 series

Rewriting the BIOS

1. Set the system to boot mode.
2. Turn off the power to the 430 series.
3. Remove the external cable and PC card.
4. Turn on the power while holding down the **F12** key. (Keep holding the key down until the system speaker sounds a beep.)
5. When the message is displayed, insert the BIOS rewrite disk into the FDD. Press **Enter** to start the BIOS rewrite.
6. When the BIOS rewrite is finished, eject the BIOS rewrite disk and press the reset switch to restart the system.

Appendix H Reliability

The following table shows MTBF (Mean Time Between Failures) for each component.

Table H-1 MTBF

Component	Time (hours)
LCD	50,000
Keyboard	40,000
HDD	300,000
FDD	20,000
CD-ROM drive	45,000
AC power unit	58,000